

PARTS MANUAL

00. MAINTENANCE

FILTERS KIT

CHASSIS: 59188

MOTOR LOMBARDINI 9LD626 / 2B2



FIGURE	REFERENCE	DENOMINATION	AMOUNT
001	LO2175040	OIL FILTER CARTRIDGE	1
002	84.00125.00	FILTER FUEL	1
003	45.01204.00	FILTER ELEMENT 60x105x300 (500H)	1
004	87.00062.00	CLEANER-PRE	1
005	LO5496074	AIR FILTER CARTRIDGE	1
006	87.00187.00	FILTER ELEMENT	1

COMMENTS

MOD.3722

00. MAINTENANCE

FILTERS KIT

CHASSIS: 69892

MOTOR LOMBARDINI 9LD626 / 2B2



FIGURE	REFERENCE	DENOMINATION	AMOUNT
001	LO2175107	OIL FILTER CARTRIDGE	1
002	84.00125.00	FILTER FUEL	1
002	KM.15500RE00	MAINTENANCE SET 1000H D250-300RM/G/A/S	1
003	45.01204.00	FILTER ELEMENT 60x105x300 (500H)	1
004	09.00630.61	OIL FILTER ASP. 25 L/MIN	1

COMMENTS

MOD.4058

02. ENGINE

MOTOR

CHASSIS: 29295

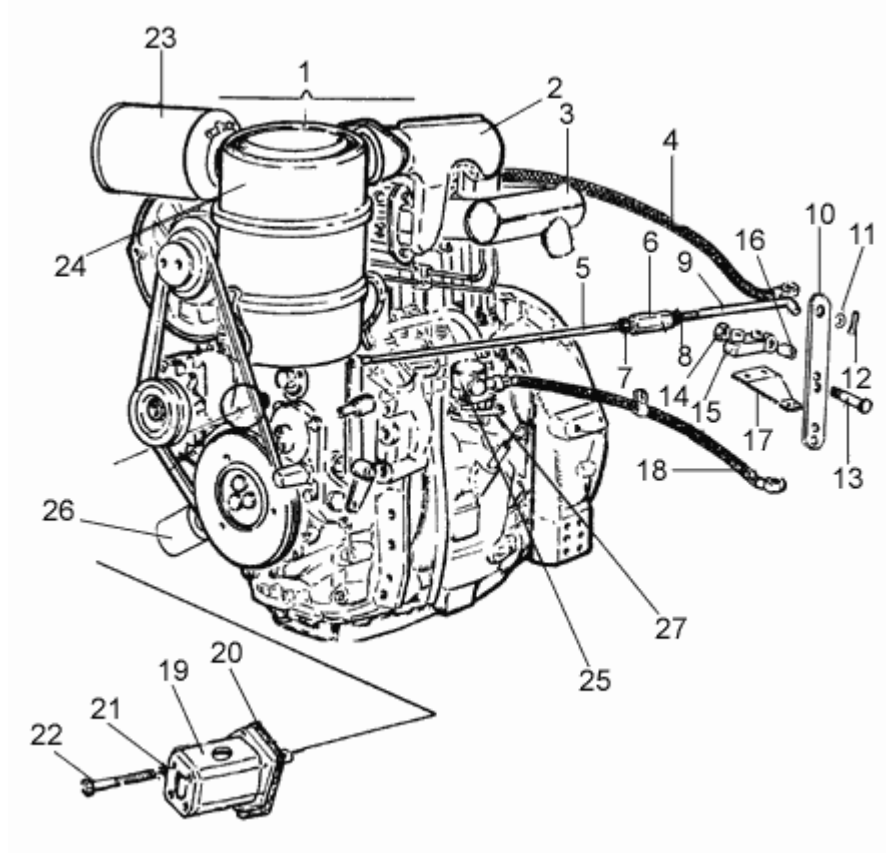

FIGURE	REFERENCE	DENOMINATION	AMOUNT
001	54.00101.02	DIESEL ENGINE	1
001	52.00101.00	DIESEL ENGINE	1
002	15.10997.00	COLECTOR ADMISION 120x168x275	1
003	15.00997.00	EXHAUST MANIFOLD	1
004	43.14105RE14	HOSE RUBBER B/P	1
005	15.00127.00	VARILLA FOR.6 625 AGU-AGU	1
006	01.00133.00	TENSIONER	1
007	701.06000.86	NUT	1
008	01.00138.00	NUT	1
009	16.00146.00	ROD L6	1
010	38.00150.00	LEVER	1
011	101.06000.66	WASHER DIN125 D6	1
012	401.02025.60	PIN DIN94 2x25	1
013	00.01366.01	AXLE 16X7X47 THROTTLE PEDAL	1
014	701.07000.66	NUT	1
015	01.00126.02	AXLE SUPPORT 20X29X60	1
016	01.00145.00	BEARING	2
017	15.10154.00	STRIP MAT.	1

02. ENGINE

MOTOR

CHASSIS: 29295

FIGURE	REFERENCE	DENOMINATION	AMOUNT
018	43.14105RE11	HOSE RUBBER B/P	1
019	15.01203.03	HYDR. PUMP	1
020	52.01352.00	PAPER GASKET	1
021	104.10000.00	WASHER DIN7980 D10	2
022	604.10110.86	SCREW DIN931	2
023	83.79009.01	AIR FILTER	1
024	83.79009.12	CLEANER-PRE	1
025	82.00310.03	FILTER ELEMENT	1
026	83.00252.06	OIL FILTER	1
027	83.25050.03	PUMP INJECTION ELEMENT	1

02. ENGINE

MOTOR

CHASSIS: 59188

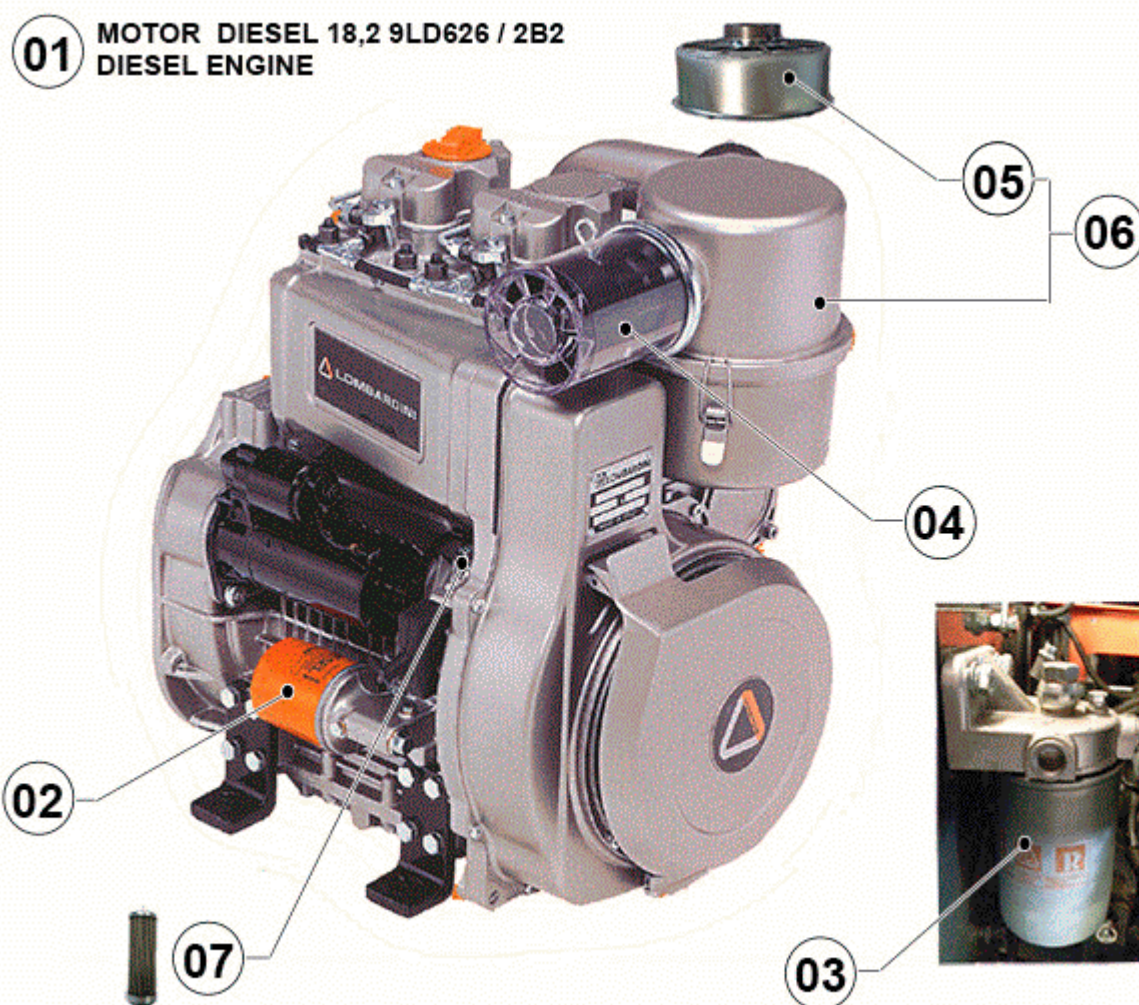

FIGURE	REFERENCE	DENOMINATION	AMOUNT
001	15.00100.05	DIESEL ENGINE 18.2KW 9LD626/2B2	1
002	LO2175040	OIL FILTER CARTRIDGE	1
003	84.00125.00	FILTER FUEL	1
004	87.00062.00	CLEANER-PRE	1
005	LO5496074	AIR FILTER CARTRIDGE	1
006	LO3700334	AIR FILTER	1
007	87.00187.00	FILTER ELEMENT	1

COMMENTS

MOD.3722

02. ENGINE

MOTOR

CHASSIS: 69892

01 MOTOR DIESEL 18,2KW 9LD626 / 2B2
DIESEL ENGINE

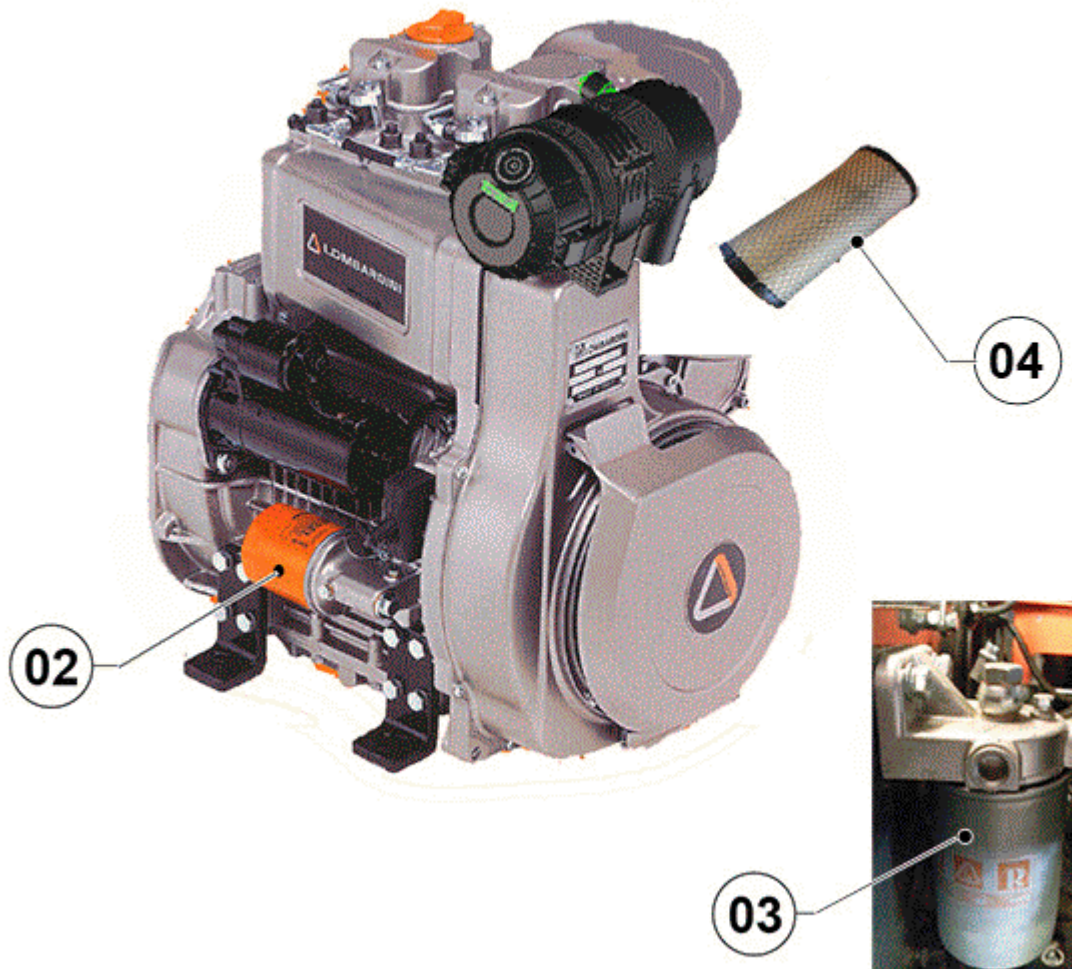

FIGURE	REFERENCE	DENOMINATION	AMOUNT
001	15.00100.06	DIESEL MOTOR 18.2 KW 9LD626 / 2B2	1
002	LO2175107	OIL FILTER CARTRIDGE	1
003	84.00125.00	FILTER FUEL	1
004	45.01204.00	FILTER ELEMENT 60x105x300 (500H)	1

COMMENTS

MOD.4058

02. ENGINE EXHAUST PIPE

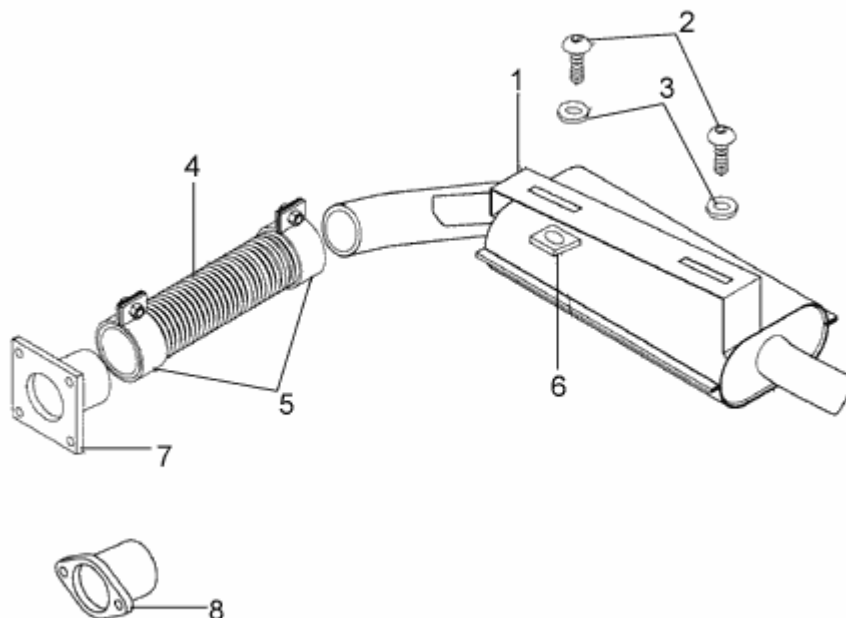

FIGURE	REFERENCE	DENOMINATION	AMOUNT
001	15.11126.02	MUFFLER RM	1
002	630.08020.96	SCREW ISO7380	2
003	112.08000.66	WASHER DIN9021 D8	2
004	43.10298.01	TUBE EXHAUST	1
005	935.51055.66	CLAMP (CH 250)	2
006	726.08004.66	NUT	2
007	55.10158.00	TUBE EXHAUST	1
008	15.10158.00	TUBE EXHAUST	1

02. ENGINE

INLET

CHASSIS: 44745

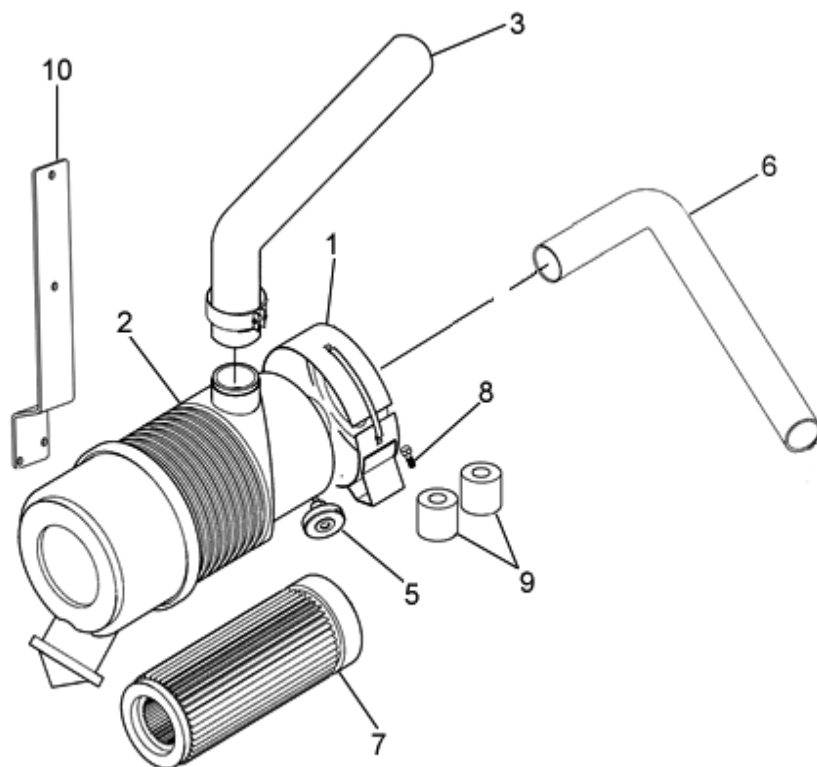

FIGURE	REFERENCE	DENOMINATION	AMOUNT
001	45.01201.11	CLAMP Ø146x50.5 AIR FILTER	1
002	45.01200.12	AIR FILTER VIRGIS	1
003	45.11194.01	ADMISSION TUBE	1
005	43.50119.00	AIR FILTER INDICATOR	1
006	49.02031.00	RUBBER HOSE B/P	1
007	45.01204.00	FILTER ELEMENT 60x105x300 (500H)	1
008	630.08060.96	SCREW ISO7380 M8x60	2
009	01.00804.01	BUSH	2
010	15.20140.00	AD. FILTER SUPPORT	1

02. ENGINE

INLET

CHASSIS: 69892

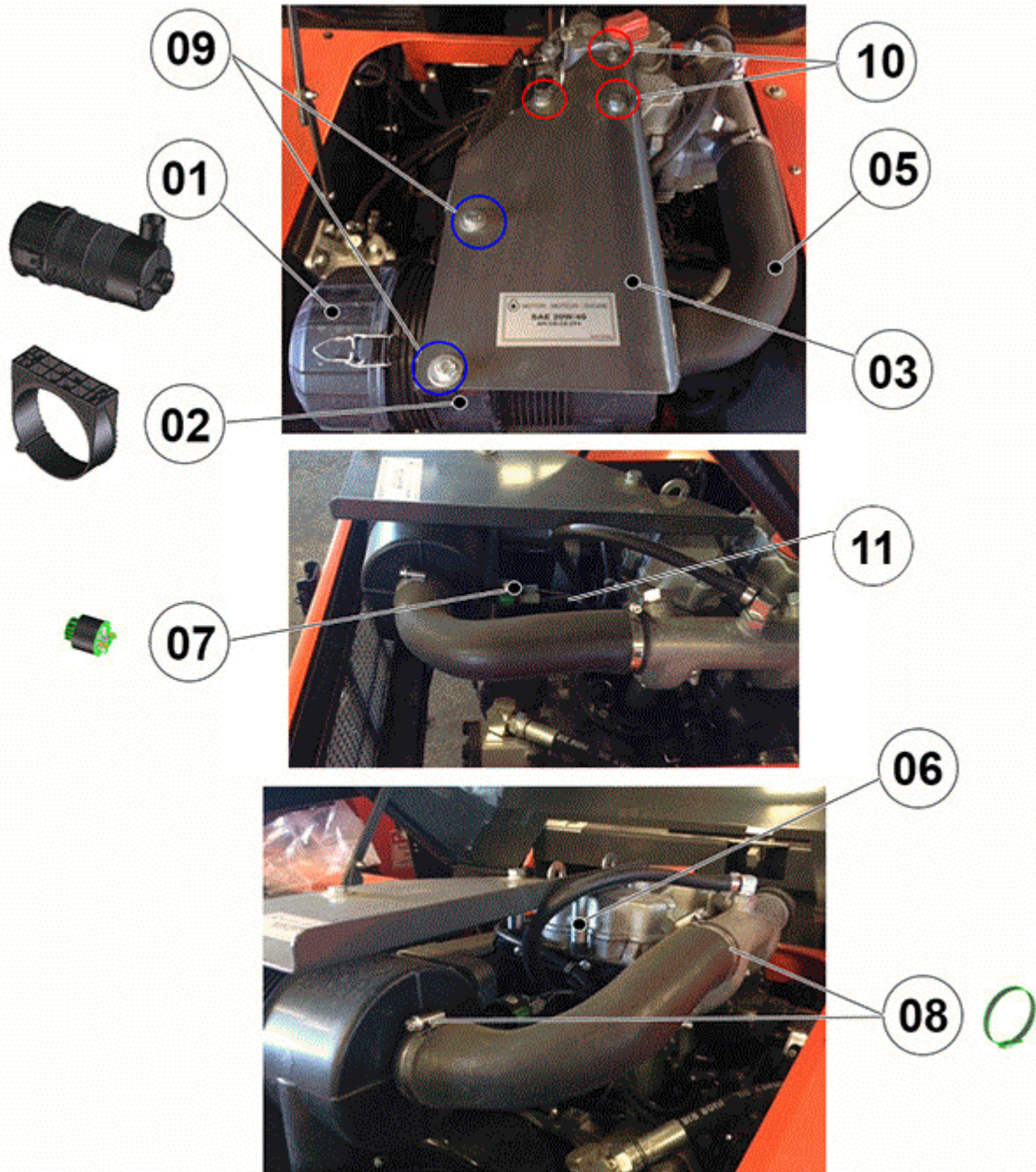

FIGURE	REFERENCE	DENOMINATION	AMOUNT
001	45.01200.12	AIR FILTER VIRGIS	1
001B	45.01204.00	FILTER ELEMENT 60x105x300 (500H)	1
002	45.01201.12	CLAMP	1
003	15.20141.00	FILTER SUPPORT	1
004	604.10050.86	BOLT DIN931 M10x50	3
005	15.04031.00	RUBBER TUBE ADMISION	1

006	15.20142.00	separator	3
007	43.50119.00	AIR FILTER INDICATOR	1
008	912.40060.66	CLAMP D40-60	2
009A	603.08030.86	SCREW DIN933 M8X30	2
009B	104.08000.00	WASHER DIN7980 D8	2
009C	701.08000.66	NUT DIN934 M8X1,25	2
010A	604.10050.86	BOLT DIN931 M10x50	3
010B	104.10000.00	WASHER DIN7980 D10	3
010C	101.10000.66	WASHER DIN125 D10	3

COMMENTS

MOD.4058

02. ENGINE ENGINE SUPPORTS

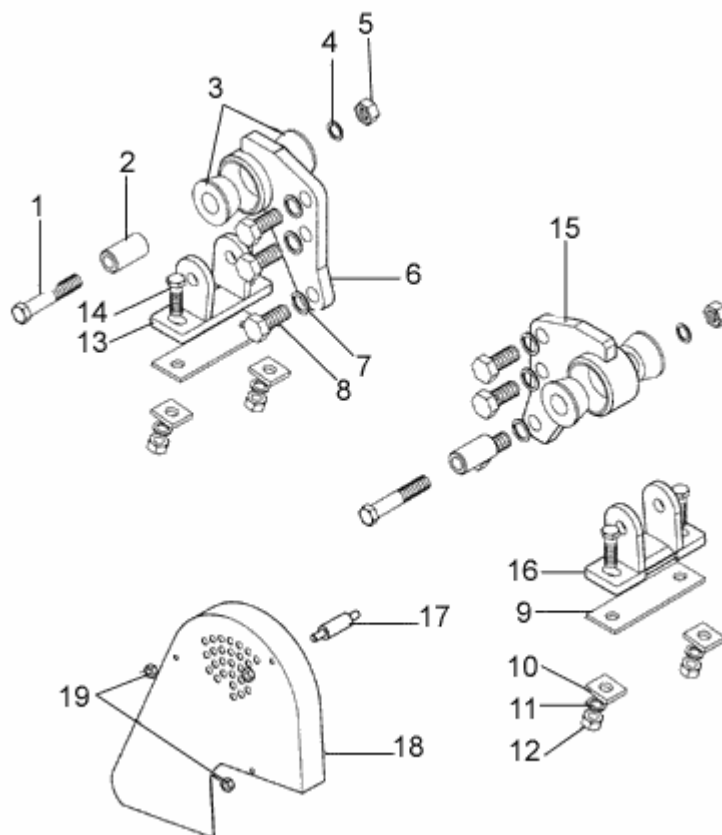

FIGURE	REFERENCE	DENOMINATION	AMOUNT
001	604.14080.86	SCREW DIN931	2
002	15.00114.00	BUSH	2
003	15.00113.00	SHOCK DAMPER 22X47X22.5 GOMA	4
004	104.14000.00	CIR-CLIP EXT. DIN7980	2
005	701.14000.66	NUT DIN934 M14x2	2
006	53.00156.00	ENGINE SUPPORT	2
007	104.06000.00	WASHER DIN7980 D6	6
008	603.16035.86	SCREW DIN933	6
009	16.00115.01	GRUESO REG. REC. 40x127x1	1
010	00.00184.00	WASHER DIN434 14X30X4.9	4
011	104.12000.00	WASHER DIN7980 D12	4
012	701.12000.66	NUT DIN934 M12x1.75	4
013	15.22116.00	ENGINE SUPPORT	1
014	603.12030.86	SCREW DIN933 M12x30	4
015	53.00156.00	ENGINE SUPPORT	1
016	15.21116.00	ENGINE SUPPORT	1
017	38.01307.00	STUD DIN938*	3
018	38.01120.00	STRAINER	1

02. ENGINE

ENGINE SUPPORTS

FIGURE	REFERENCE	DENOMINATION	AMOUNT
019	701.06000.66	NUT DIN934 M6X1	3

02. ENGINE

ENGINE SUPPORTS

CHASSIS: 59188

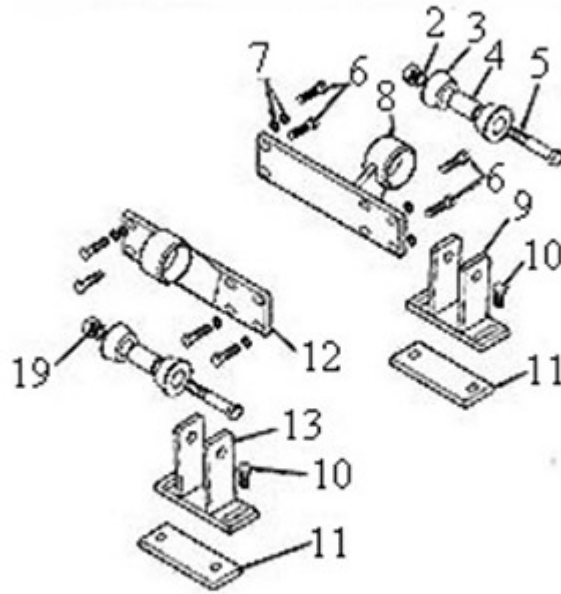

FIGURE	REFERENCE	DENOMINATION	AMOUNT
002	104.14000.00	CIR-CLIP EXT. DIN7980	2
003	15.00113.00	SHOCK DAMPER 22X47X22.5 GOMA	4
004	15.00114.00	BUSH	2
005	604.14080.86	SCREW DIN931	2
006	603.10025.86	SCREW DIN933 M10x25	12
007	104.10000.00	WASHER DIN7980 D10	12
008	15.00112.03	ENGINE SUPPORT	1
009	15.21116.00	ENGINE SUPPORT	1
010	603.12030.86	SCREW DIN933 M12x30	4
011	16.00115.01	GRUESO REG. REC. 40x127x1	2
011	16.00115.01	GRUESO REG. REC. 40x127x1	2
012	15.00112.02	ENGINE SUPPORT	1
013	15.22116.00	ENGINE SUPPORT	1

014

01.00855.00

ACC. FORK

1

COMMENTS

MOD.3722

02. ENGINE

ISUZU ENGINE SUPPORTS

CHASSIS: 44745

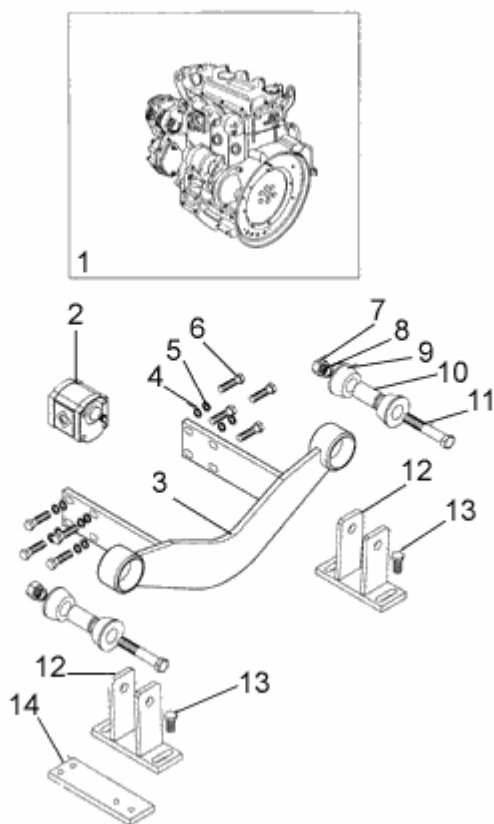

FIGURE	REFERENCE	DENOMINATION	AMOUNT
001	43.10101.03	DIESEL ENGINE	1
002	15.01157.00	HYDR. PUMP (ISUZU)	1
003	43.00718.00	ENGINE SUPPORT	1
004	101.10000.66	WASHER DIN125 D10	8
005	104.10000.00	WASHER DIN7980 D10	8
006	603.10025.86	SCREW DIN933 M10x25	8
007	701.14000.86	NUT	2
008	104.14000.00	CIR-CLIP EXT. DIN7980	2
009	15.00113.00	SHOCK DAMPER 22X47X22.5 GOMA	2
010	15.00114.00	BUSH	4
011	43.00134.00	SCREW	2
012	15.22116.00	ENGINE SUPPORT	2
013	603.10030.86	SCREW DIN933	4
014	15.02050.00	MAT. REC. 16X80X260	1

02. ENGINE CLUTCH LOMBARDINI-DITER

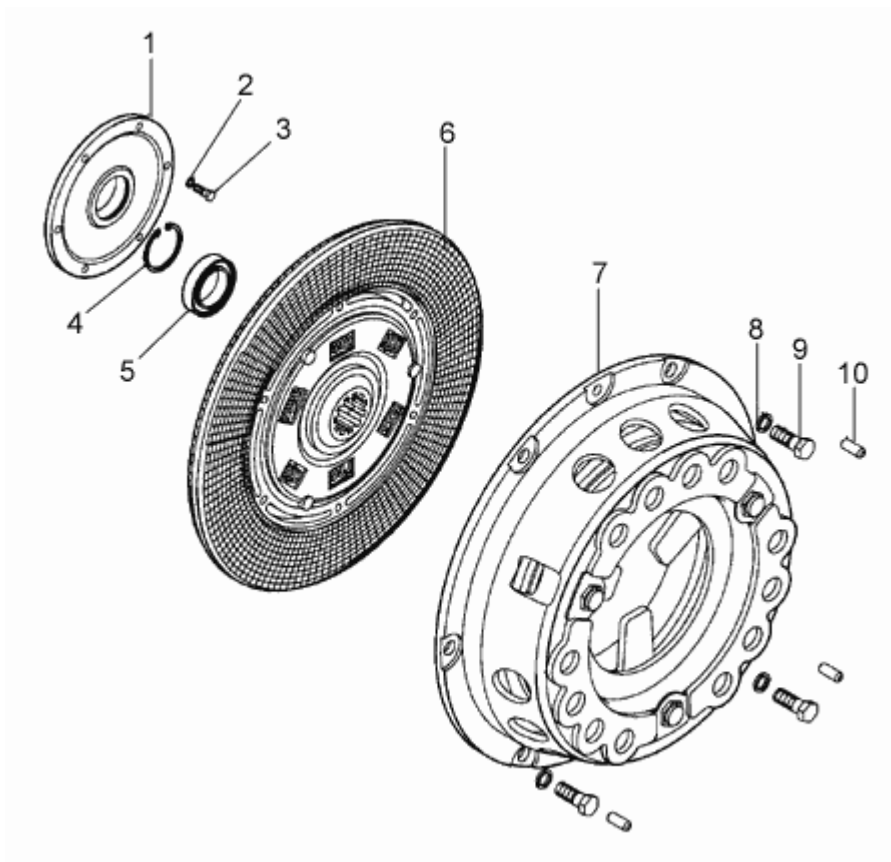

FIGURE	REFERENCE	DENOMINATION	AMOUNT
001	43.00121.00	BEARING SUPPORT	1
002	104.06000.00	WASHER DIN7980 D6	6
003	603.06020.86	SCREW DIN933 M6x20	6
004	905.40000.00	RING 0,5 MM.	1
005	309.17012.00	BEARING DIN625	1
006	43.00201.00	DISK CLUTCH	1
008	104.10000.00	WASHER DIN7980 D10	6
009	603.10020.86	SCREW DIN933 M10x20	6
010	402.08020.00	PIN DIN1481 8x20	2

02. ENGINE

CLUTCH LOMBARDINI-DITER

CHASSIS: 59188

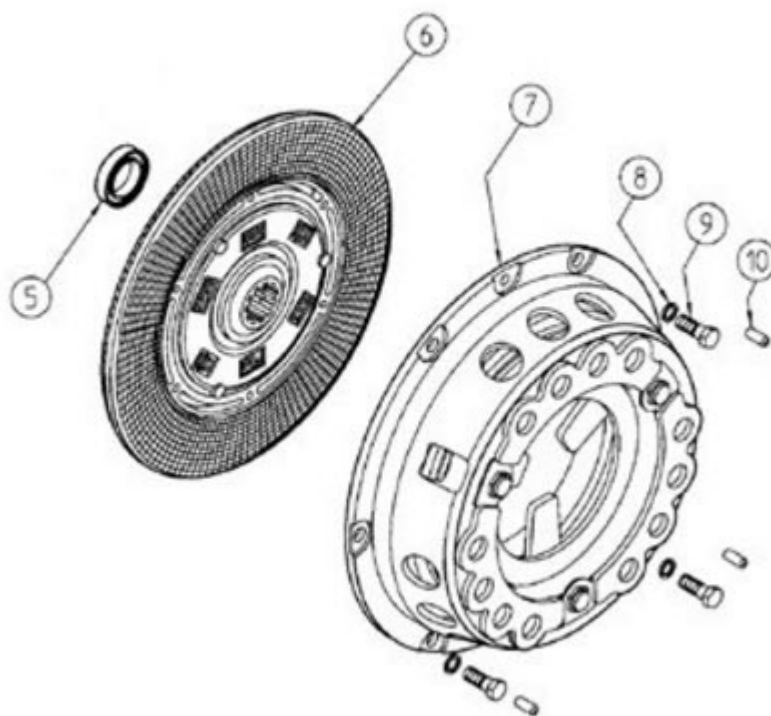

FIGURE	REFERENCE	DENOMINATION	AMOUNT
005	309.17012.00	BEARING DIN625	1
006	43.00201.00	DISK CLUTCH	1
007	43.00202.11	PRESSURE PLATE	1
008	104.10000.00	WASHER DIN7980 D10	6
009	603.10020.86	SCREW DIN933 M10x20	6
010	402.08020.00	PIN DIN1481 8x20	2

COMMENTS

MOD.3722

02. ENGINE CLUTCH ISUZU

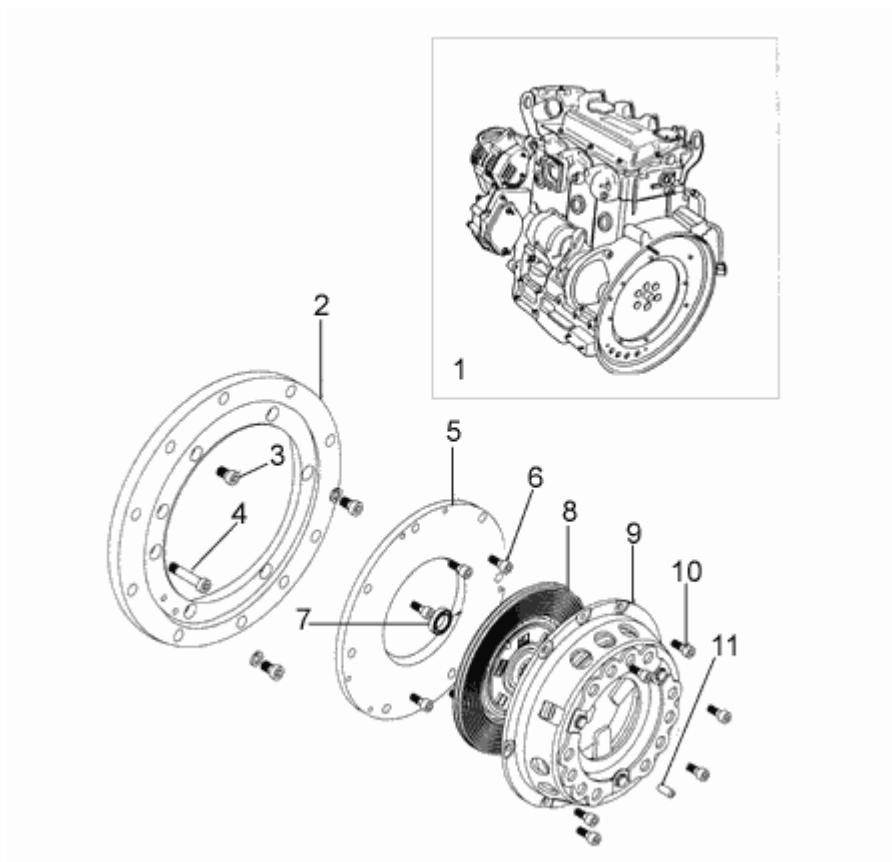
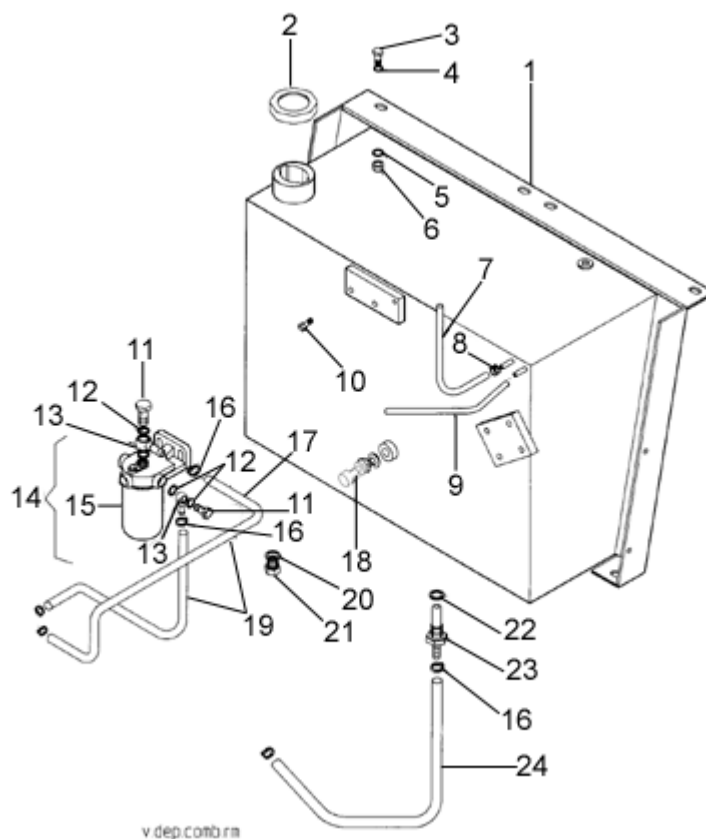

FIGURE	REFERENCE	DENOMINATION	AMOUNT
001	05.60410.02	DIESEL ENGINE	1
001	43.10101.01	ENGINE DIESEL (3LD1)	1
002	43.10060.20	ACOP. CIL/CIL 403x403x18 MOTOR	1
003	601.10025.86	SCREW DIN912	8
004	601.10110.86	SCREW DIN912	2
005	43.10061.20	FLY WHEEL ENGINE	1
006	43.08034.00	SCREW DIN912*	6
007	309.17012.00	BEARING DIN625	1
008	43.00201.03	DISK CLUTCH	1
009	43.00202.01	CONJ.PRESION 10 9 MUELLES	1
010	601.10020.86	SCREW DIN912 M10x20	6
011	402.08020.00	PIN DIN1481 8x20	2

02. ENGINE

GAS-OIL TANK

CHASSIS: 35217



vdep.com.br

FIGURE	REFERENCE	DENOMINATION	AMOUNT
001	15.10728.02	TANK	1
002	15.01524.00	TANK CAP	1
003	603.10030.86	SCREW DIN933	3
004	01.00837.00	CIR-CLIP INT. DIN9021*	3
005	104.10000.00	WASHER DIN7980 D10	3
006	701.10000.66	NUT DIN934 M10x1.5	3
007	43.14105.16	TUBO GOMA B/P 4x9x300	1
008	931.05370.00	CLAMP TAPE 5x370	3
009	43.14105.16	TUBO GOMA B/P 4x9x300	1
010	603.08030.86	SCREW DIN933 M8X30	3
011	80.06035.00	NIPPLE SCREW SIM.	2
012	107.12000.10	WASHER AL	4
013	37.00130.02	NIPPLE O/TB	2
014	15.10100RE00	FILTER FUEL with suport	1
015	MN000029	FUEL FILTER GASOIL	1
016	912.08016.66	CLAMP DIN3017	3
017	43.14105.41	TUBO GOMA B/P 8x14x480	2
018	43.70261RE00	BUOY OIL LEVEL INDICATOR	1

02. ENGINE

GAS-OIL TANK

CHASSIS: 35217

FIGURE	REFERENCE	DENOMINATION	AMOUNT
019	43.14105.19	TUBO GOMA B/P 8x14x760	2
019	43.14105.39	TUBO GOMA B/P 4x9x440	2
020	107.14000.10	WASHER AL 14x20x1.5	1
021	00.02803.00	SCREW DIN910*	1
022	106.14000.20	WASHER CU	1
023	52.00110.02	FITTING M/M 14x9	1
024	43.14105.34	TUBO GOMA B/P 8x14x300	1

02. ENGINE

ACCELERATOR

CHASSIS: 59188

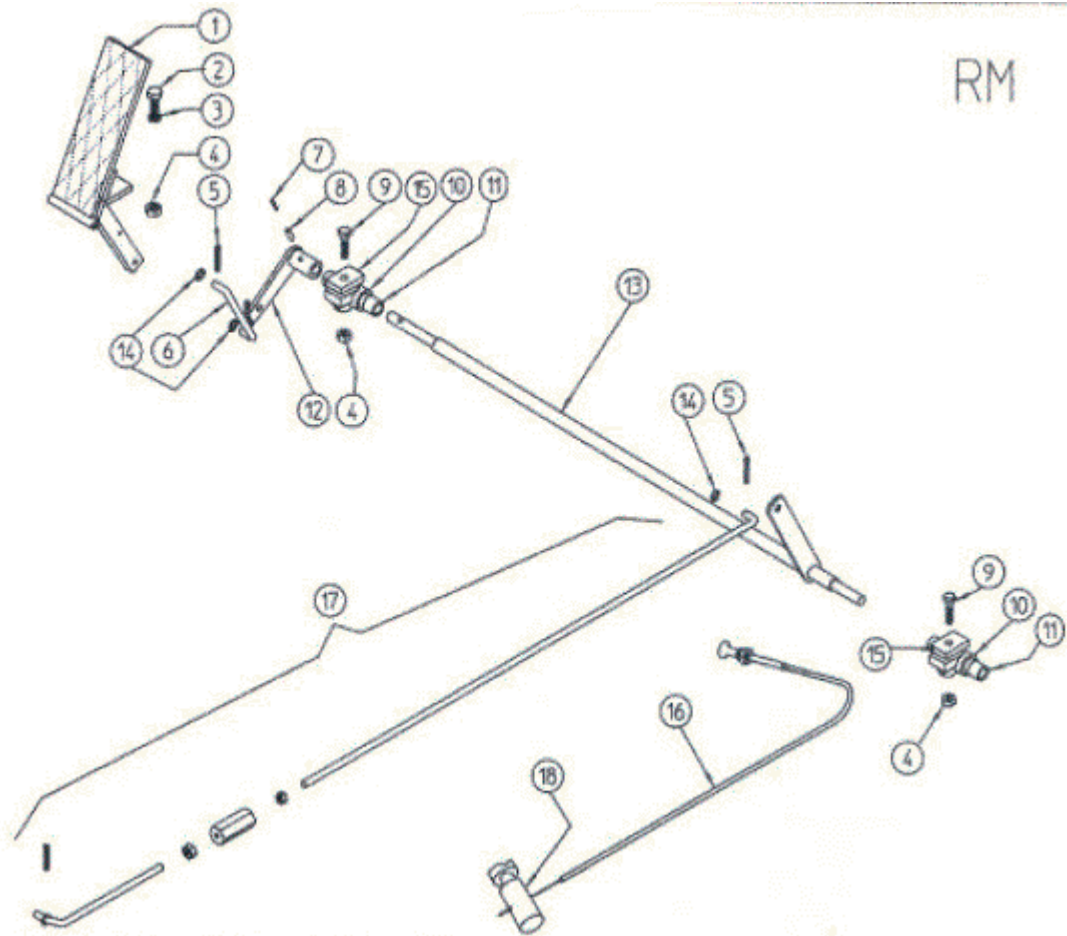

FIGURE	REFERENCE	DENOMINATION	AMOUNT
001	60.00125.01	PEDAL ACELERADOR COMP.	1
002	603.06020.86	SCREW DIN933 M6x20	2
003	101.06000.66	WASHER DIN125 D6	2
004	701.06000.66	NUT DIN934 M6X1	2
005	401.02025.60	PIN DIN94 2x25	4
006	46.00128.00	ROD U6	1
007	402.25016.00	PIN	2
008	402.04016.00	ROLL PIN DIN1481 4x16	2
009	604.06040.86	SCREW DIN931 M6x40	2
010	15.00124.03	BEARING	2
011	01.00145.00	BEARING	2
012	16.00151.00	ACC.LEVER	1
013	15.30124.00	LEVER	1
014	101.07000.66	WASHER DIN125	4
015	15.30126.00	REGUL SPACER	2
016	16.00148.01	CABLE CHOKE	1
017	53.01520RE00	ROD	1



018

45.03150.00

LATCH

1

COMMENTS

MOD.3722

TRANSMISSION TRANSMISSION FIXATING

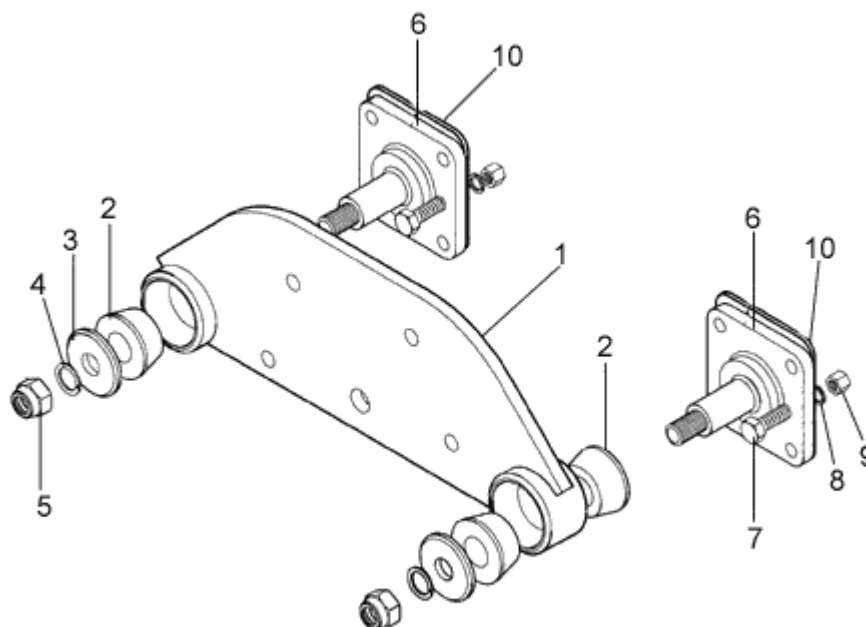

FIGURE	REFERENCE	DENOMINATION	AMOUNT
001	15.00372.01	SUPPORT PLATE	1
002	15.00113.00	SHOCK DAMPER 22X47X22.5 GOMA	4
003	15.00374.00	CIR-CLIP INT. DIN9021*	2
004	104.16000.00	CIR-CLIP EXT. DIN7980	2
005	708.16000.66	NUT	2
006	15.00373.00	AXLE CPL/ROS	2
007	604.10030.86	SCREW DIN931	8
008	104.10000.00	WASHER DIN7980 D10	8
009	701.10000.66	NUT DIN934 M10x1.5	8
010	15.00373.01	GRUESO REG. REC. 4x94x94	4

TRANSMISSION GEARBOX

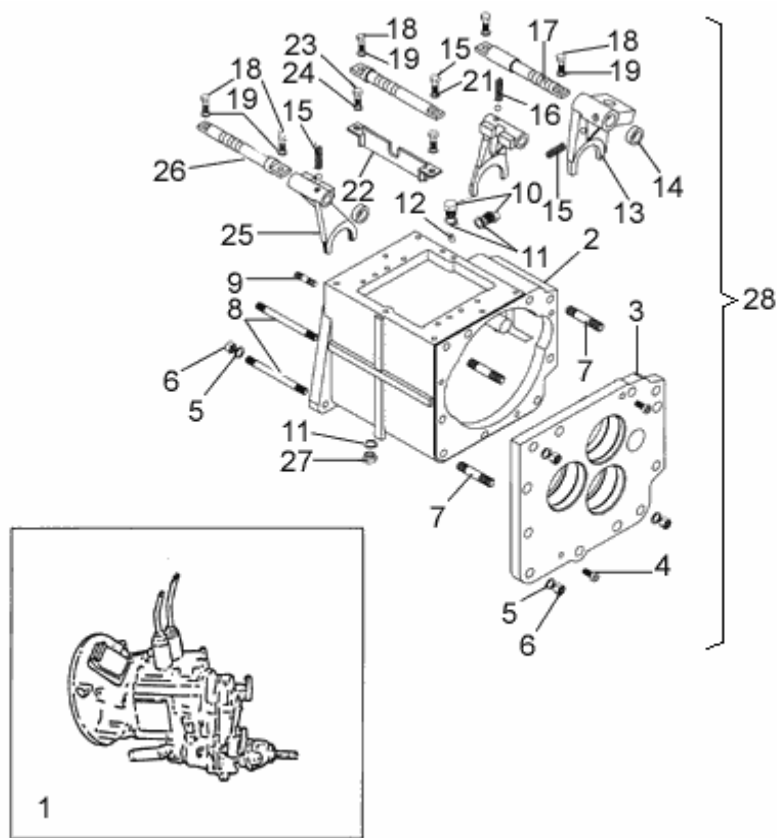

FIGURE	REFERENCE	DENOMINATION	AMOUNT
001	15.00300.42	CONJ. CAJA C/V D/T	1
001	15.00300.41	CONJ. CAJA C/V D/T (COMPEN)	1
002	15.00348.00	CASING	1
002	15.00348.01	CASING	1
003	15.00349.00	FLANGE	1
004	601.08020.86	SCREW DIN912	3
005	104.12000.00	WASHER DIN7980 D12	12
006	701.12000.66	NUT DIN934 M12x1.75	12
007	08.00113.00	STUD DIN939	9
008	15.00355.00	STUD DIN939	4
009	15.00357.00	STUD DIN939 M12x1,75	2
010	00.02803.00	SCREW DIN910*	2
011	107.14000.10	WASHER AL 14x20x1.5	2
012	01.00335.00	MAGNET	1
013	15.00313.00	ACC. FORK	1
014	15.00329.00	BUSH	2
015	15.00315.00	SPRING COMPRESSION	3
016	908.08000.00	BALL	3

**TRANSMISSION
GEARBOX**

FIGURE	REFERENCE	DENOMINATION	AMOUNT
017	15.00314.00	AXLE REC/REC	1
018	01.01205.00	SCREW DIN931*	6
019	104.08000.00	WASHER DIN7980 D8	6
020	15.00325.00	AXLE REC/REC	1
021	15.00324.00	ACC. FORK	1
022	15.00335.00	PLATE	1
023	603.08020.86	SCREW DIN933 M8x20	2
024	104.08000.00	WASHER DIN7980 D8	2
025	15.00327.00	ACC. FORK	1
026	15.00328.00	AXLE REC/REC	1
027	10.00921.00	CAP M14X150 DIN908	1
028	15.00310RE01	GEAR BOX ASSY (COMPEN)	1
028	15.00310RE00	GEAR BOX ASSY	1

COMMENTS

2 - With COMPEN

TRANSMISSION SPEED CHANGE

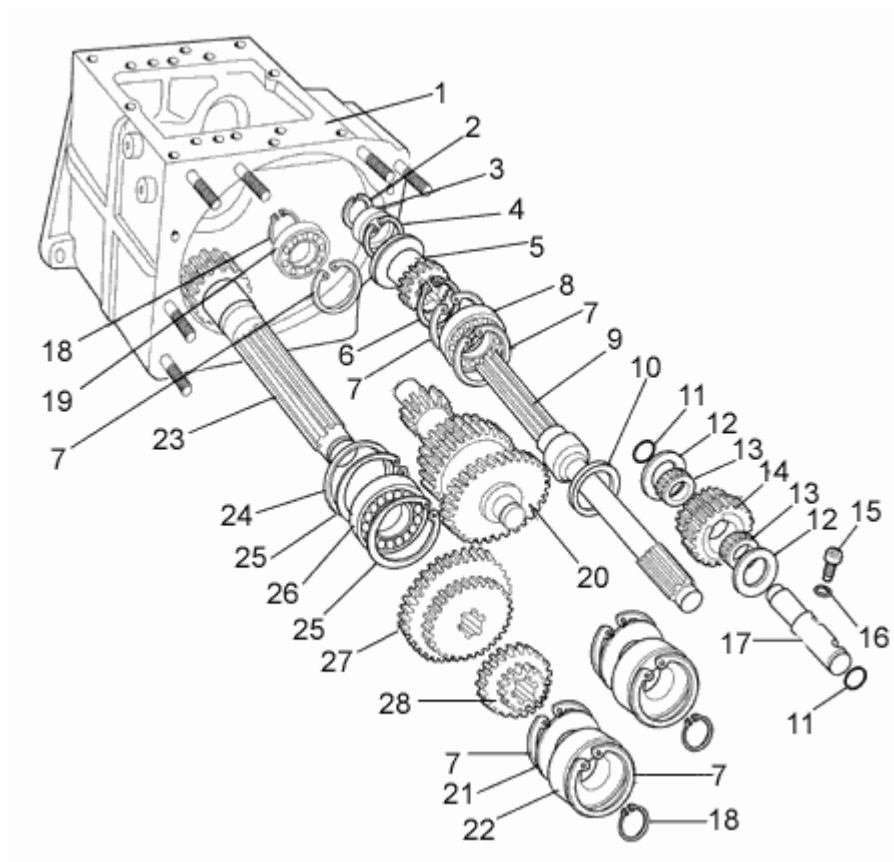

FIGURE	REFERENCE	DENOMINATION	AMOUNT
001	15.00348.01	CASING	1
002	904.20000.00	RING 0,5 MM.	1
003	306.20015.00	BEARING DIN5412	1
004	905.52000.00	RING 0,5 MM.	1
005	15.00312.00	GEAR z16 50x65x54	1
006	904.30000.00	RING 0,5 MM.	1
007	905.62000.00	RING 0,5 MM.	7
008	301.30016.00	BEARING DIN625	1
009	15.00311.01	SHAFT CIL/CIL	1
010	202.34075.50	SEAL DIN3760	1
011	201.18002.50	O-RING DIN3770	2
012	15.00342.00	WASHER DIN126*	2
013	308.22017.00	NEEDLES	2
014	15.00343.00	GEAR z21-18	1
015	15.00344.00	SCREW DIN931*	1
016	104.08000.00	WASHER DIN7980 D8	1
017	15.00341.00	AXLE CIL/CPA	1
018	904.25000.00	RING 0,5 MM.	3

TRANSMISSION SPEED CHANGE

FIGURE	REFERENCE	DENOMINATION	AMOUNT
019	306.25017.00	BEARING DIN5412	1
020	16.00309.01	SHAFT CAS/CAS	1
021	15.03584.00	WASHER ADJUST.	1
022	301.25017.00	BEARING DIN625	1
023	15.00322.00	SHAFT CAS/CIL	1
024	202.40010.50	SEAL DIN3760	1
025	905.72000.00	RING 0,5 MM.	2
026	316.35023.00	BEARING DIN625	1
027	15.00323.00	GEAR z37-28	1
028	15.00326.00	GEAR z22-17	1

TRANSMISSION GEARBOX

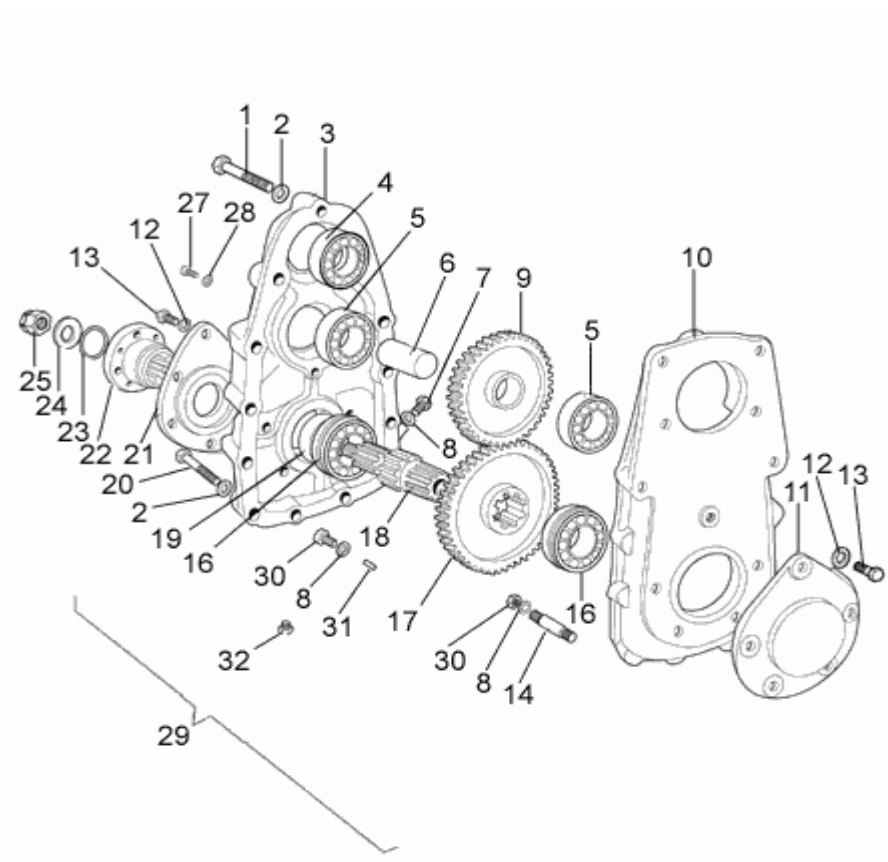

FIGURE	REFERENCE	DENOMINATION	AMOUNT
001	604.10060.86	SCREW DIN931	1
002	104.10000.00	WASHER DIN7980 D10	7
003	15.00369.01	FLANGE	1
004	312.35021.00	BEARING DIN5412	1
005	301.35021.00	BEARING DIN625	2
006	15.00364.00	SHAFT CIL/CON	1
007	00.02803.00	SCREW DIN910*	1
008	107.14000.10	WASHER AL 14x20x1.5	2
009	15.00363.00	GEAR z40	1
010	15.00360.01	FLANGE	1
011	15.00370.00	FLANGE	1
012	104.12000.00	WASHER DIN7980 D12	10
013	603.12030.86	SCREW DIN933 M12x30	12
014	15.00361.01	STUD DIN939*	2
015	701.12000.66	NUT DIN934 M12x1.75	2
016	311.40023.00	BEARING DIN625	2
017	15.00365.00	GEAR z51	1
018	15.00366.01	SHAFT DEN/ROS	1

**TRANSMISSION
GEARBOX**

FIGURE	REFERENCE	DENOMINATION	AMOUNT
019	202.50010.50	SEAL DIN3760	1
020	604.10065.86	SCREW DIN931	6
021	15.00371.00	FLANGE	1
022	15.00367.01	COUPLING CYL/CYL	1
023	201.37003.50	O-RING DIN3770	1
024	15.00368.00	WASHER DIN1440*	1
025	710.20000.66	NUT DIN935 M20x1,5	1
026	401.35040.60	PIN	1
027	601.10015.86	SCREW DIN912	1
028	106.10000.20	WASHER CU 10x16x1,5 DIN7603A	1
029	55.00302RE00	GEARBOX	1
030	00.02803.00	SCREW DIN910*	1
031	01.00335.00	MAGNET	1
032	10.00921.00	CAP M14X150 DIN908	1

TRANSMISSION
CLUTCH BELL HOUSING
CHASSIS: 34159

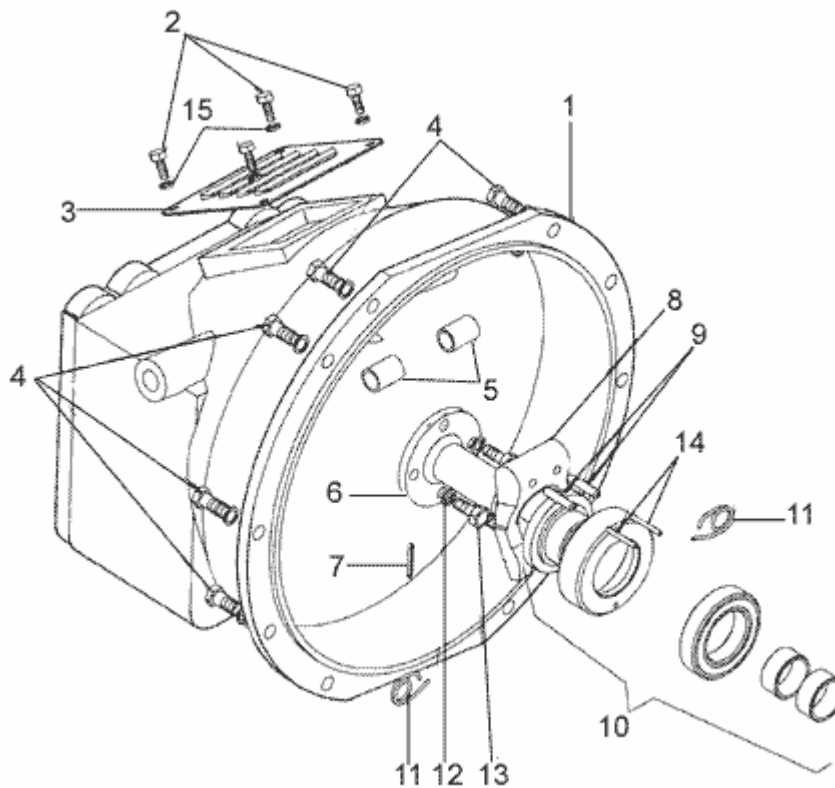

FIGURE	REFERENCE	DENOMINATION	AMOUNT
001	52.00211.01	CLUTCH CASING	1
002	603.06015.86	SCREW DIN933 M6x15	4
003	15.00213.10	COVER HANDHOLE	1
004	603.10030.86	SCREW DIN933	12
005	940.25018.00	BUSH	2
006	01.00235.00	BEARING SUPPORT	1
007	401.35040.60	PIN	1
008	01.00222RE02	FORK	1
009	402.06030.00	PIN	2
010	16.00204RE04	THROWOUT BEARING	1
011	01.00220.01	SPRING TORSION	1
012	104.08000.00	WASHER DIN7980 D8	4
013	603.08020.86	SCREW DIN933 M8x20	4
014	402.35030.00	PIN	2
015	104.06000.00	WASHER DIN7980 D6	4

TRANSMISSION

CLUTCH BELL HOUSING

CHASSIS: 59188



FIGURE	REFERENCE	DENOMINATION	AMOUNT
00	15.00306.10	CLUTCH BELL	1
001	43.00211.10	CLUTCH CASING	1
002	603.06015.86	SCREW DIN933 M6x15	4
003	15.00213.10	COVER HANDHOLE	1
004	603.10030.86	SCREW DIN933	12
005	940.25018.00	BUSH	2
006	01.00235.00	BEARING SUPPORT	1
007	401.35040.60	PIN	1
008	01.00222RE02	FORK	1
009	402.06030.00	PIN	2
010	16.00204RE03	THROWOUT BEARING	1

011	01.00220.01	SPRING TORSION	1
012	104.08000.00	WASHER DIN7980 D8	4
013	603.08020.86	SCREW DIN933 M8x20	4
014	402.35030.00	PIN	2
015	104.06000.00	WASHER DIN7980 D6	4

COMMENTS

MOD.3722

TRANSMISSION

GEARS LEVERS

CHASSIS: 20547

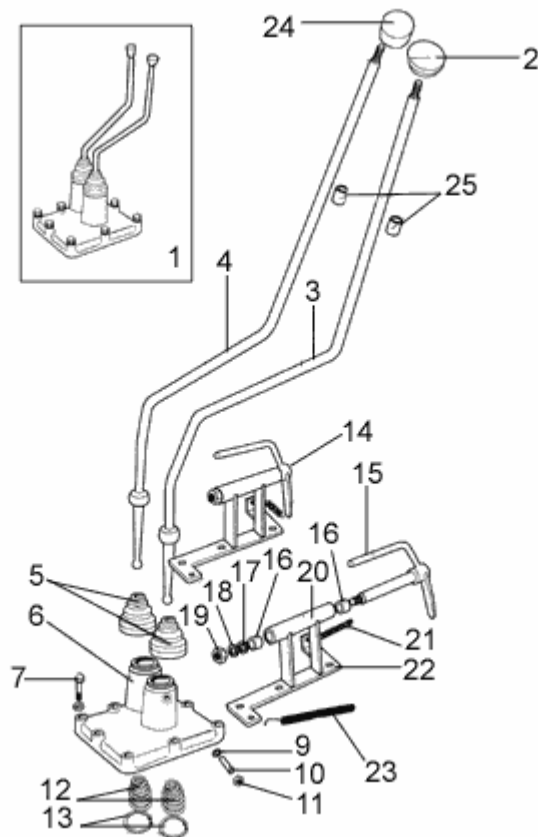

FIGURE	REFERENCE	DENOMINATION	AMOUNT
001	15.03070.02	TAPA SOP. C/P COMP.	1
002	01.00325.03	KNOB	1
003	15.00353.04	CONTROL LEVER SHIFT SPEED	1
004	15.00354.04	F-R CONTROL LEVER	1
005	00.00326.00	DUST EXCLUDER	2
006	15.00352.00	COVER HANDHOLE	1
007	604.08045.86	SCREW DIN931 M8x45	4
007	604.08050.86	SCREW DIN931	4
008	104.08000.00	WASHER DIN7980 D8	8
009	104.10000.00	WASHER DIN7980 D10	2
010	01.00312.00	SCREW DIN417*	2
011	701.09000.66	NUT	2
012	01.00326.00	SPRING COMPRESSION	2
013	905.45000.00	RING 0,5 MM.	2
014	15.00380.01	SOP. EJE 22,5x15x10	1
015	43.00354.01	ACC.LEVER	1
016	923.16030.00	BEARING	2
017	101.12000.66	WASHER DIN125 D12	1

TRANSMISSION**GEARS LEVERS**

CHASSIS: 20547

FIGURE	REFERENCE	DENOMINATION	AMOUNT
018	104.12000.00	WASHER DIN7980 D12	1
019	701.12000.66	NUT DIN934 M12x1.75	1
020	901.08000.33	GREASER DIN71412-A M8x1,25	1
021	45.00139.00	SPRING TENSION	1
022	43.00351.01	AXLE SUPPORT	1
023	43.00355.00	SPRING TENSION	1
024	01.00325.02	EMPU \ Adur D50X79 C / V	1
025	15.10327.00	CASQUILLO GOMA 12x22x27	2

TRANSMISSION

REAR TRANSMISSION COUPLING

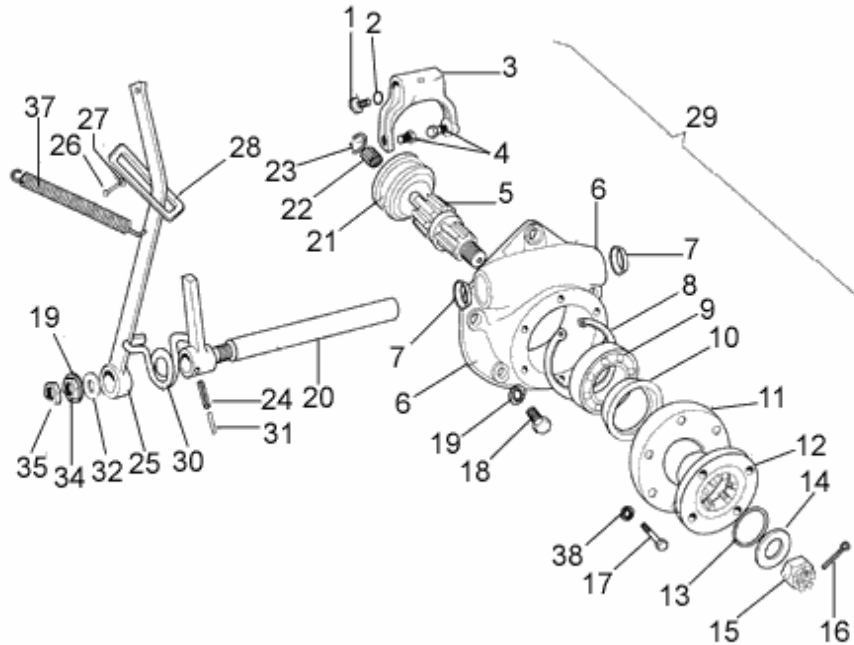

FIGURE	REFERENCE	DENOMINATION	AMOUNT
001	15.00575.01	SCREW DIN933*	7
002	104.10000.00	WASHER DIN7980 D10	7
003	15.00573.00	ACC. FORK	1
004	15.00574.00	AXLE CIL/COR	2
005	15.00577.00	AXLE CAS/ROS	1
006	15.00571.00	AXLE SUPPORT	1
007	202.18008.50	SEAL DIN3760	2
008	905.80000.00	RING 0,5 MM.	1
009	301.35021.00	BEARING DIN625	1
010	202.50010.50	SEAL DIN3760	1
011	15.00578.00	COVER HANDHOLE	1
012	15.00367.01	COUPLING CYL/CYL	1
013	201.37003.50	O-RING DIN3770	1
014	15.00368.02	WASHER	1
015	710.20000.66	NUT DIN935 M20x1,5	1
016	401.04035.60	PIN	1
017	604.08035.86	SCREW DIN931	6
018	603.12030.86	SCREW DIN933 M12x30	5

TRANSMISSION

REAR TRANSMISSION COUPLING

FIGURE	REFERENCE	DENOMINATION	AMOUNT
019	104.12000.00	WASHER DIN7980 D12	5
020	15.05830.00	AXLE CIL/ROS	1
021	15.00576.00	BUSH	1
022	308.16017.00	NEEDLES	1
023	911.16000.00	RING 0,5 MM.	1
024	402.06030.00	PIN	2
025	15.00579.02	CONTROL LEVER	1
026	603.06015.86	SCREW DIN933 M6x15	2
027	104.06000.00	WASHER DIN7980 D6	2
028	15.00580.00	TIE ROD	1
029	15.00507.01	CONJ. ACOP. TRANS.	1
030	15.00581.00	SPRING TORSION	1
031	402.35030.00	PIN	2
032	101.12000.66	WASHER DIN125 D12	1
033	104.08000.00	WASHER DIN7980 D8	6
034	701.12000.66	NUT DIN934 M12x1.75	1
035	708.12000.66	NUT	1
036	15.05830.00	AXLE CIL/ROS	1
037	43.00355.00	SPRING TENSION	1

TRANSMISSION

CLUTCH OPERATION

CHASSIS: 44745

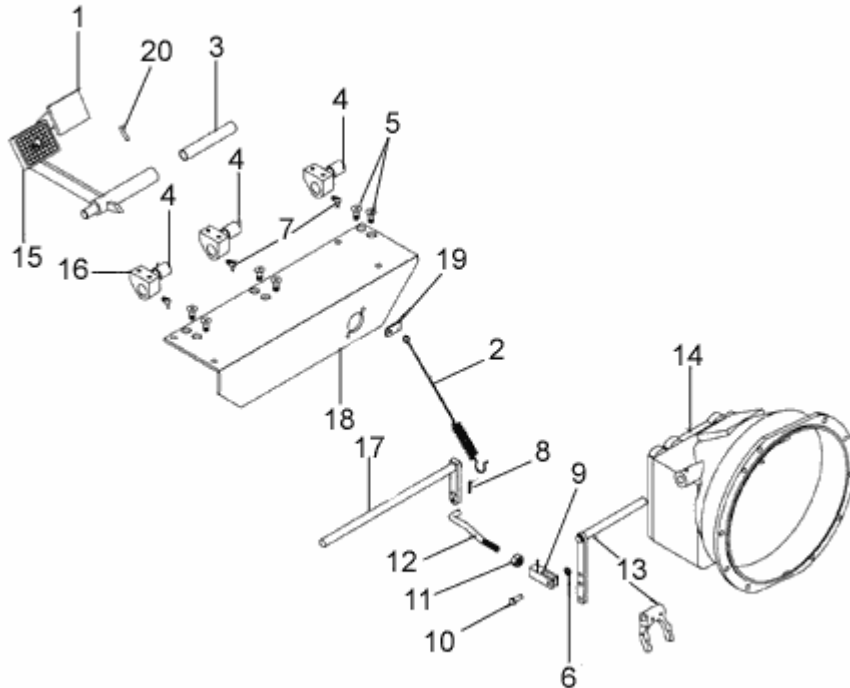

FIGURE	REFERENCE	DENOMINATION	AMOUNT
001	15.10240.00	PEDAL EMBR. 194X194X225	1
002	01.00223.02	SPRING TENSION	1
003	15.10741.00	PANEL	1
004	923.18030.00	BEARING	3
005	618.08020.86	SCREW DIN7991 M8x20	1
006	101.08000.66	WASHER DIN125 D8	1
007	902.08000.33	GREASER DIN71412-C	1
008	401.02025.60	PIN DIN94 2x25	1
009	01.00564.01	ART. FORK	1
010	01.00514.01	AXLE CIL/CPA 14x8x28	1
011	01.01304.00	NUT	1
012	15.00216.06	ROD F7/16	1
013	15.00301re02	SHAFT CIL/CIL	1
013	15.00301re02	SHAFT CIL/CIL	1
014	52.00211.01	CLUTCH CASING	1
015	43.07310.01	PANEL	1
016	43.00736.00	SUPPORT ART.	3
017	15.10241.00	ACC.LEVER	1

TRANSMISSION**CLUTCH OPERATION**

CHASSIS: 44745

FIGURE	REFERENCE	DENOMINATION	AMOUNT
018	15.10726.01	SOP. BOMBA PIE 119.5X170X539	3
019	45.04113.10	STRIP SUPPORT	1
020	402.06030.00	PIN	1

03. TRANSMISSION REDUCTION BOX WITH COMPEN

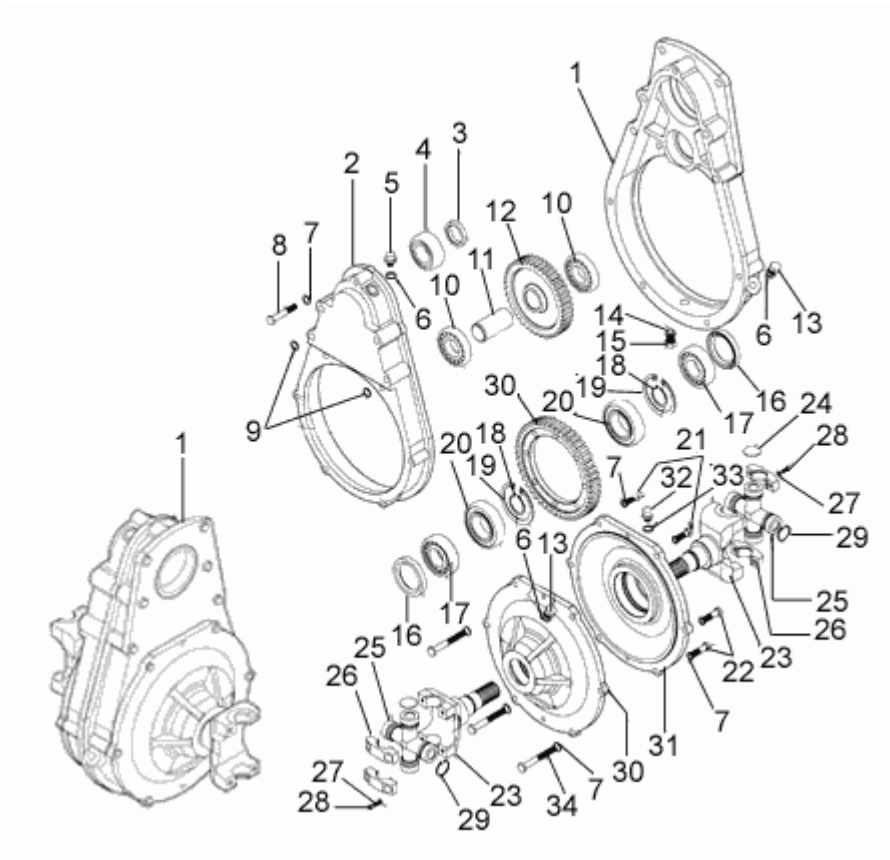

FIGURE	REFERENCE	DENOMINATION	AMOUNT
001	15.00360.15	BOX.	1
002	15.00369.14	FLANGE	1
003	15.00399.00	REGUL SKIM	1
004	312.35023.00	BEARING DIN5412	1
005	80.01035.00	SCREW DIN910*	1
006	106.14000.20	WASHER CU	3
007	104.10000.00	WASHER DIN7980 D10	13
008	604.10060.86	SCREW DIN931	1
009	201.11275.50	O-RING DIN3770	4
010	301.35014.00	BEARING DIN625	2
011	15.00364.00	SHAFT CIL/CON	1
012	15.00363.00	GEAR z40	1
013	00.02803.00	SCREW DIN910*	2
014	01.00335.00	MAGNET	1
015	10.00921.00	CAP M14X150 DIN908	1
016	205.50010.50	SEAL DIN3760	2
017	301.35021.00	BEARING DIN625	2
018	905.80000.00	RING 0,5 MM.	2

03. TRANSMISSION REDUCTION BOX WITH COMPEN

FIGURE	REFERENCE	DENOMINATION	AMOUNT
019	904.35000.00	RING 0,5 MM.	2
020	312.45019.00	BEARING DIN5412	2
021	603.10025.86	SCREW DIN933 M10x25	4
022	603.10035.86	SCREW DIN933 M10x35	4
023	43.03789.00	ART. FORK	2
024	15.00554.00	REGUL SKIM	10
025	15.48110.00	AXLES	2
026	43.00380.01	CLAMP	4
027	104.08000.00	WASHER DIN7980 D8	4
028	601.08015.86	SCREW DIN912	4
029	905.30000.00	RING 0,5 MM.	4
030	15.00365.16	WHEEL RIM	1
031	15.00375.01	COVER	2
032	52.00365.00	CAP	1
033	107.14000.10	WASHER AL 14x20x1.5	1
034	604.10080.86	SCREW DIN931	4

03. TRANSMISSION SYSTEM COMPEN (PERMANENT 4WD SYSTEM)

PERMANENT 4WD SYSTEM

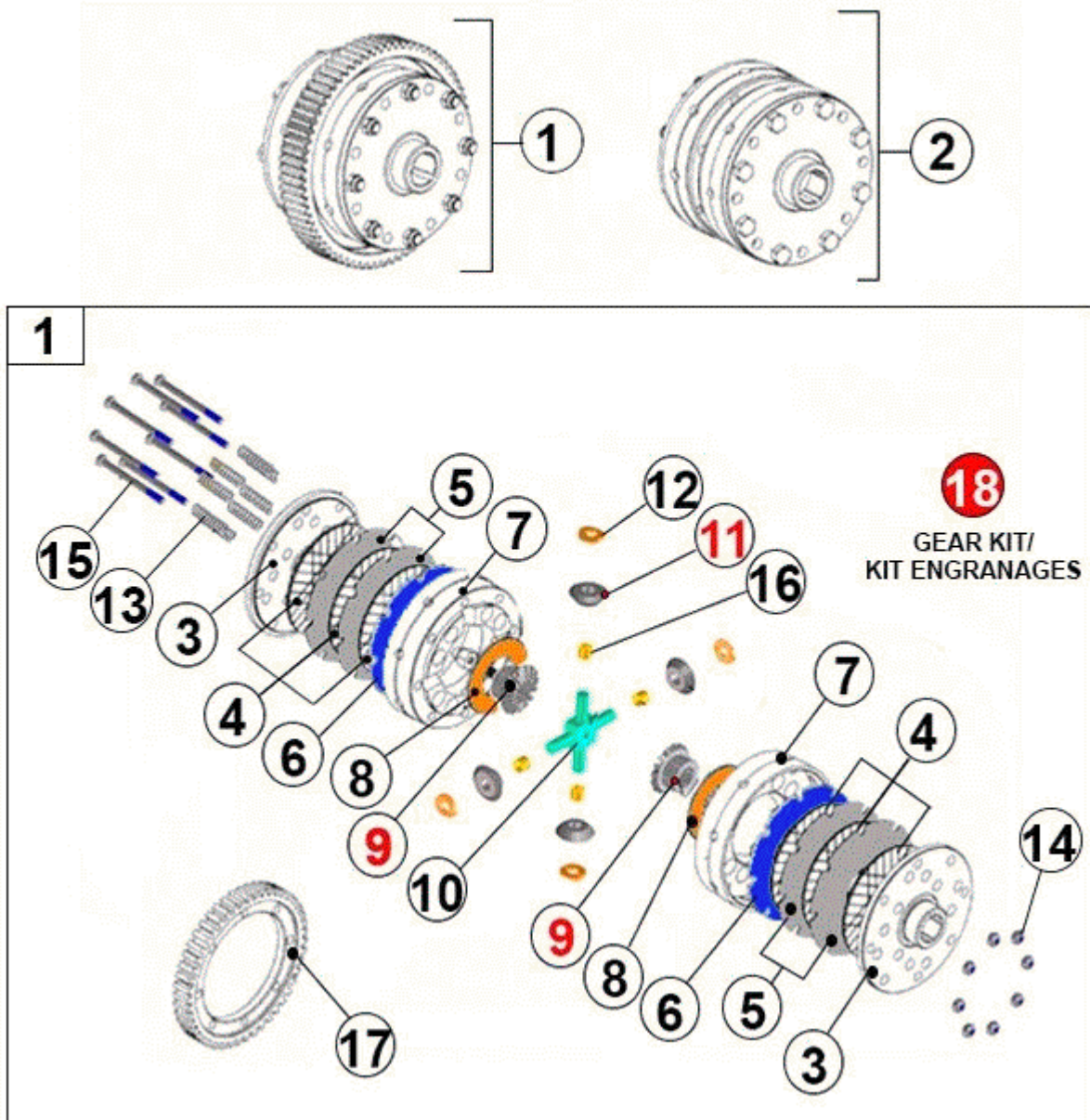

FIGURE	REFERENCE	DENOMINATION	AMOUNT
001	15.00359RE00	DIFFERENTIAL	1
002	43.03600RE00	COMPEN DIFFERENTIAL WITHOUT CROWN	1
003	43.00371.00	FLANGE	2
004	43.03690.00	DISK AXIAL	6
005	43.00368.00	DISK AXIAL	4
006	43.00367.00	DISK AXIAL	2
007	43.00360.10	CASING	2
008	43.00374.01	REGUL SKIM	1
008	43.00374.02	REGUL SKIM	1
008	43.00374.03	REGUL SKIM	1

010	43.00362.02	SHAFT CIL/CIL	1
012	43.00364.01	PANEL	4
013	43.00366.00	SPRING COMPRESSION	4
014	711.10000.66	SHOCK ABSORBER	8
015	604.10120.80	SCREW DIN931	8
016	939.01415.00	BUSH	8
017	15.00365.16	WHEEL RIM	1
018	43.00304.00	GEAR KIT II	1

TRANSMISSION HOUSINGS AND AXLES

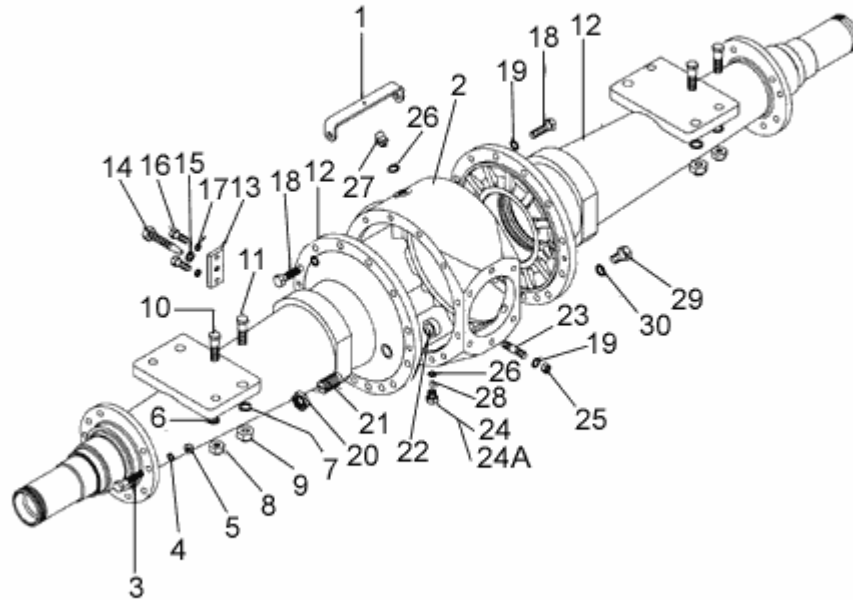

FIGURE	REFERENCE	DENOMINATION	AMOUNT
001	43.50499.01	STRIGHT SUPPORT	1
002	15.00524.11	CASING	1
003	604.10045.90	SCREW DIN931	16
004	104.10000.00	WASHER DIN7980 D10	16
005	711.10000.66	SHOCK ABSORBER	16
006	101.14000.66	WASHER DIN125 D14	4
007	101.16000.66	WASHER DIN125 D16	4
008	711.14000.66	NUT DIN982 M14 8.8 K	4
009	711.16000.66	NUT DIN982 M16 8.8 K	4
010	604.14060.86	SCREW DIN931	4
011	604.16060.86	SCREW DIN931	4
012	43.50422.00	ASCLE HOUSING	2
013	15.00483.00	COVER HANDHOLE	2
014	15.00484.00	SCREW DIN933*	2
015	701.10000.66	NUT DIN934 M10x1.5	2
016	603.08020.86	SCREW DIN933 M8x20	4
017	104.08000.00	WASHER DIN7980 D8	4
018	625.12045.90	SCREW DIN931	26

TRANSMISSION HOUSINGS AND AXLES

FIGURE	REFERENCE	DENOMINATION	AMOUNT
018	625.12035.86	SCREW	4
019	104.12000.00	WASHER DIN7980 D12	30
020	709.22000.66	NUT	1
021	15.00428.00	SCREW DIN564*	1
022	15.00429.00	SLIPPING BUTT	1
023	15.00357.00	STUD DIN939 M12x1,75	6
024	10.00921.00	CAP M14X150 DIN908	2
025	701.12000.80	NUT	6
026	107.14000.10	WASHER AL 14x20x1.5	3
027	52.00365.00	CAP	1
028	01.00335.00	MAGNET	1
029	45.10803.10	CAP M22x1,5	1
030	08.00316.00	METALLIC GASKET BUNA D1/2 G	1
24A	80.01035.01	CAP	1

TRANSMISSION GEAR SUPPORT AND BRAKE 250/300 RM

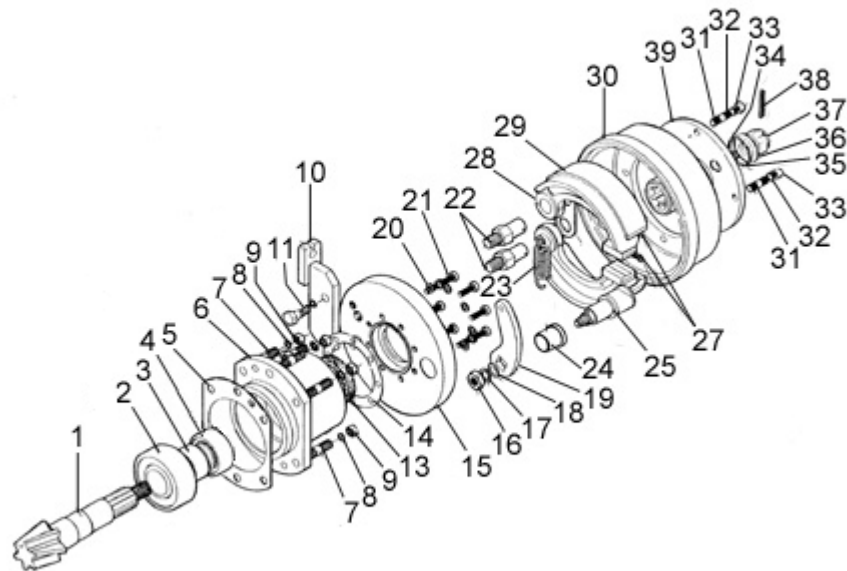

FIGURE	REFERENCE	DENOMINATION	AMOUNT
001	15.50000.02	CONICAL GEAR SET	1
002	323.40033.00	BEARING DIN5412	1
003	43.00431.01	BUSH	1
004	307.35227.00	BEARING DIN720	1
005	15.04342.00	WASHER ADJUST.	1
005	15.04343.00	WASHER ADJUST.	1
005	15.04344.00	WASHER ADJUST.	1
006	43.00430.03	GEAR SUPPORT	1
007	15.00357.00	STUD DIN939 M12x1,75	6
008	104.12000.00	WASHER DIN7980 D12	6
009	701.12000.80	NUT	6
010	55.00761.00	FIXING SUPPORT	1
011	604.12030.86	SCREW DIN931	2
012	104.12000.00	WASHER DIN7980 D12	2
013	202.50010.50	SEAL DIN3760	1
014	43.04302.00	WASHER ADJUST.	1
015	58.00421.01	FLANGE	1
016	01.01306.00	NUT	1

TRANSMISSION

GEAR SUPPORT AND BRAKE 250/300 RM

FIGURE	REFERENCE	DENOMINATION	AMOUNT
017	104.14000.00	CIR-CLIP EXT. DIN7980	1
018	101.13000.66	WASHER DIN125	1
019	55.00520.00	LEVER	1
020	601.08030.86	SCREW DIN912 M8x30	8
021	104.08000.00	WASHER DIN7980 D8	8
022	15.00757.00	AXLE CPA/ROS	2
023	00.00515.00	SPRING TENSION	1
024	15.00712.00	BEARING	1
025	00.00516.00	CAM	1
026	00.00512.00	PANEL	1
027	401.03040.60	PIN	2
028	15.00709.00	BRAKE SHOE	2
029	15.07111.00	LINING BRAKESHOE	2
030	15.00713.01	BRAKE DRUMP	2
031	15.00435.01	STUD DIN938 33 M10x1.5	4
032	104.10000.00	WASHER DIN7980 D10	4
033	701.10000.66	NUT DIN934 M10x1.5	4
034	15.00457.01	SCREW DIN931*	4
035	201.37003.50	O-RING DIN3770	1
037	710.20000.66	NUT DIN935 M20x1,5	1
038	401.04035.60	PIN	1
039	58.04260.00	COUPLING CYL/CYL	1

TRANSMISSION

GEAR SUPPORT AND BRAKE 250/300 RM

CHASSIS: 40782

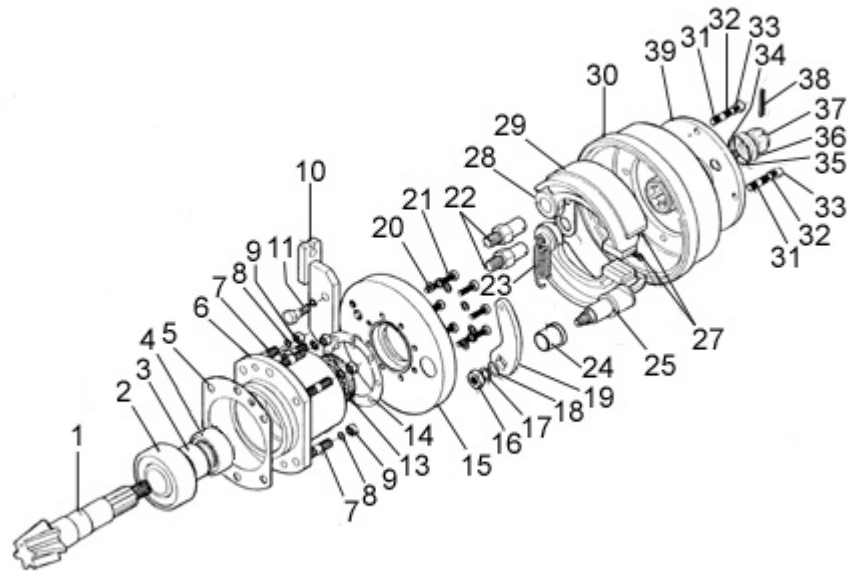

FIGURE	REFERENCE	DENOMINATION	AMOUNT
001	15.50000.04	CONICAL GEAR SET	1
002	307.40035.00	BEARING DIN720	1
004	307.35033.00	BEARING DIN720	1
005	15.04342.00	WASHER ADJUST.	1
005	15.04343.00	WASHER ADJUST.	1
005	15.04344.00	WASHER ADJUST.	1
006	43.00430.04	GEAR SUPPORT	1
007	15.00357.00	STUD DIN939 M12x1,75	6
008	104.12000.00	WASHER DIN7980 D12	6
009	701.12000.80	NUT	6
010	55.00761.00	FIXING SUPPORT	1
011	604.12030.86	SCREW DIN931	2
012	104.12000.00	WASHER DIN7980 D12	2
013	202.50010.50	SEAL DIN3760	1
014	43.04302.00	WASHER ADJUST.	1
015	58.00421.01	FLANGE	1
016	01.01306.00	NUT	1
017	104.14000.00	CIR-CLIP EXT. DIN7980	1

TRANSMISSION

GEAR SUPPORT AND BRAKE 250/300 RM

CHASSIS: 40782

FIGURE	REFERENCE	DENOMINATION	AMOUNT
018	101.13000.66	WASHER DIN125	1
019	55.00520.00	LEVER	1
020	601.08030.86	SCREW DIN912 M8x30	8
021	104.08000.00	WASHER DIN7980 D8	8
022	15.00757.00	AXLE CPA/ROS	2
023	00.00515.00	SPRING TENSION	1
024	15.00712.00	BEARING	1
025	00.00516.00	CAM	1
026	00.00512.00	PANEL	1
027	401.03040.60	PIN	2
028	15.00709.00	BRAKE SHOE	2
029	15.07111.00	LINING BRAKESHOE	2
030	15.00713.01	BRAKE DRUMP	2
031	15.00435.01	STUD DIN938 33 M10x1.5	4
032	104.10000.00	WASHER DIN7980 D10	4
033	701.10000.66	NUT DIN934 M10x1.5	4
034	15.00457.01	SCREW DIN931*	4
035	201.37003.50	O-RING DIN3770	1
036	15.00368.01	WASHER	1
037	710.20000.66	NUT DIN935 M20x1,5	1
038	401.04035.60	PIN	1
039	58.04260.00	COUPLING CYL/CYL	1

TRANSMISSION

DIFFERENTIAL HOUSING AND GEAR

CHASSIS: 31677

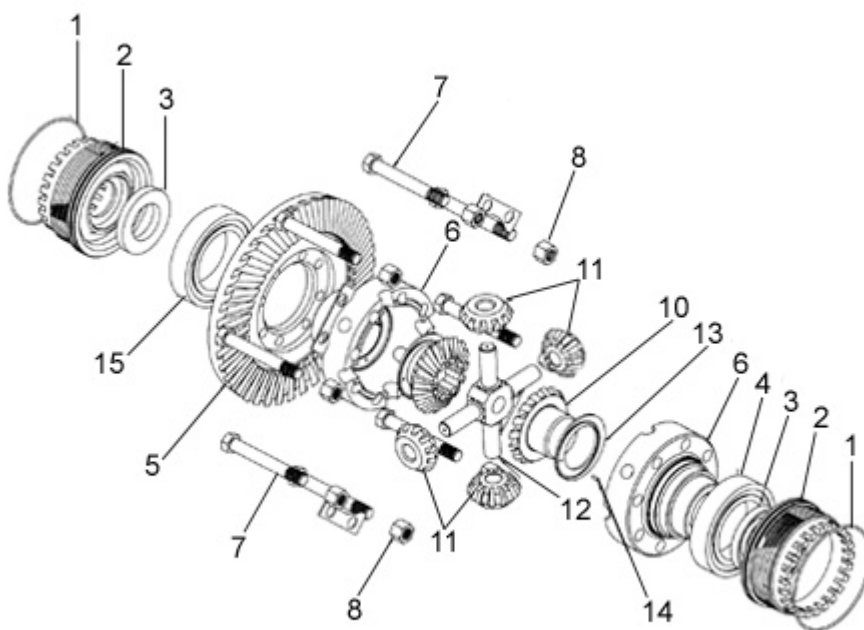

FIGURE	REFERENCE	DENOMINATION	AMOUNT
001	201.12025.50	O-RING DIN3770	2
002	15.00424.01	COVER HANDHOLE	2
003	202.42010.50	SEAL DIN3760	2
004	301.70024.00	BEARING DIN625	1
005	15.50000.04	CONICAL GEAR SET	1
006	15.04100RE00	DIFFERENTIAL HOUSING	1
007	15.00418.00	SCREW DIN931*	8
008	718.14000.80	NUT	8
009	nulo	nulo	1
010	15.00416.01	GEAR CONICAL	2
011	15.00415.01	GEAR CONICAL	4
012	15.00414.00	AXLES	1
013	15.00411.02	ADJUSTABLE WASHER 52.25x77x3	2
014	403.03010.00	PIN DIN6325 3x10	2
015	303.70024.00	BEARING DIN628 7214-B	1

TRANSMISSION SHAFTS AND HUBS

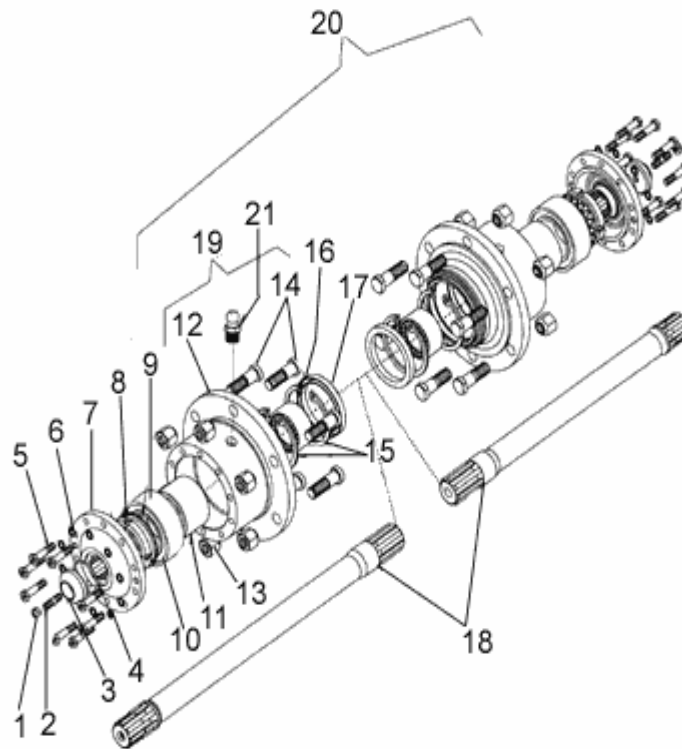

FIGURE	REFERENCE	DENOMINATION	AMOUNT
001	711.10000.66	SHOCK ABSORBER	2
002	15.01034.00	STUD DIN938* 41 M10x1,5	2
003	15.00451.00	WASHER DIN125*	2
004	201.48003.50	O-RING DIN3770	2
005	604.10045.90	SCREW DIN931	20
006	104.10000.00	WASHER DIN7980 D10	20
007	15.00450.00	COUPLING CYL/GEA	2
008	907.65012.00	NUT	2
009	906.65000.00	WASHER	2
010	304.65038.00	BEARING DIN628	2
011	43.00449.00	BUSH	2
012	43.00448.03	WHEEL HUB	2
013	15.00453.00	NUT	12
014	15.00452.00	SCREW FASTENING WHEEL	12
015	905.10000.00	RING 0,5 MM.	4
016	321.70030.00	BEARING DIN617	2
017	202.80100.50	SEAL DIN3760	2
018	43.50445.00	DRIVE SHAFT	2

TRANSMISSION SHAFTS AND HUBS

FIGURE	REFERENCE	DENOMINATION	AMOUNT
019	43.00403.01	CUBO RUEDA C/TORNILLO COMP.	2
020	43.00406.10	CUBO RUEDA COMP.	2
021	901.08000.33	GREASER DIN71412-A M8x1,25	2

TRANSMISSION BRAKE 250-300 RM

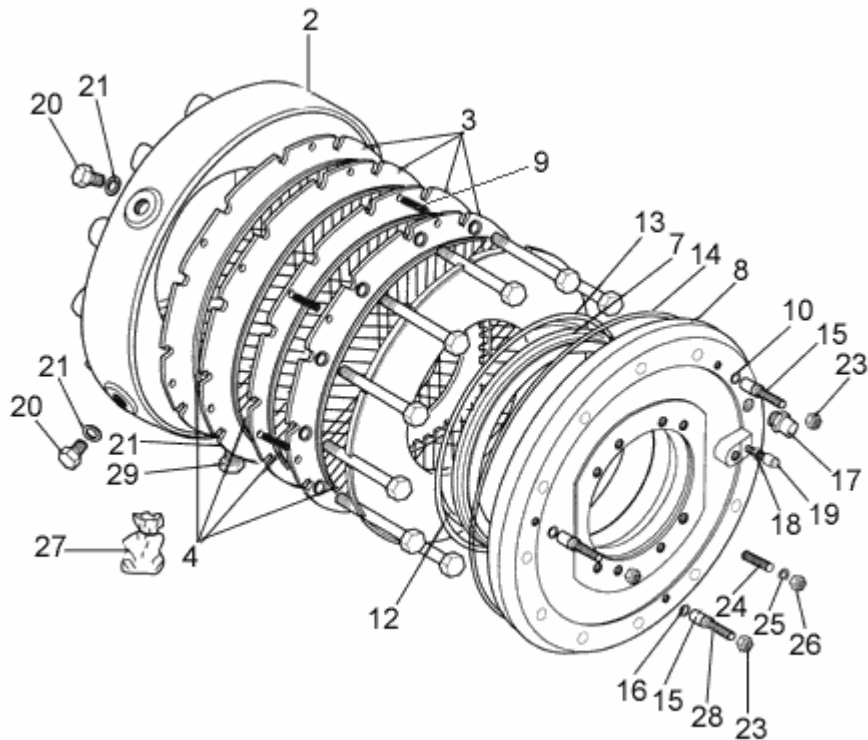

FIGURE	REFERENCE	DENOMINATION	AMOUNT
001	15.00403RE10	DISK BRAKE	2
002	15.00470.00	CASING	1
003	15.00469.00	DISK BRAKE	4
004	15.00473.00	DISK BRAKE	4
005	202.14412.50	SEAL DIN3760	1
006	15.00467.00	DISK BRAKE	1
007	15.00466.00	PISTON	1
008	15.00465.00	BRAKE PLATE	1
009	15.00472.00	SPRING COMPRESSION	6
010	15.00471.00	SCREW DIN931*	12
011	106.10000.20	WASHER CU 10x16x1,5 DIN7603A	12
012	201.19004.50	O-RING DIN3770	1
013	201.21004.50	O-RING DIN3770	1
014	201.28703.50	O-RING DIN3770	1
015	15.00475.01	AXLE CIL/COR	3
016	201.05025.50	O-RING DIN3770	3
017	52.00365.00	CAP	1
018	43.00408.41	SCREW DIN564*	1

**TRANSMISSION
BRAKE 250-300 RM**

FIGURE	REFERENCE	DENOMINATION	AMOUNT
019	45.00408.41	CAP	1
020	80.01035.01	CAP	2
021	107.14000.10	WASHER AL 14x20x1.5	3
022	201.11503.50	O-RING DIN3770	1
023	701.08000.86	NUT	3
024	15.00476.00	STUD M10x47	8
025	104.10000.00	WASHER DIN7980 D10	8
026	711.10000.66	SHOCK ABSORBER	8
027	43.99403RE00	GASKET SET	1
028	622.08025.86	SCREW DIN916	3
029	10.00921.00	CAP M14X150 DIN908	1

TRANSMISSION

REAR AXLE

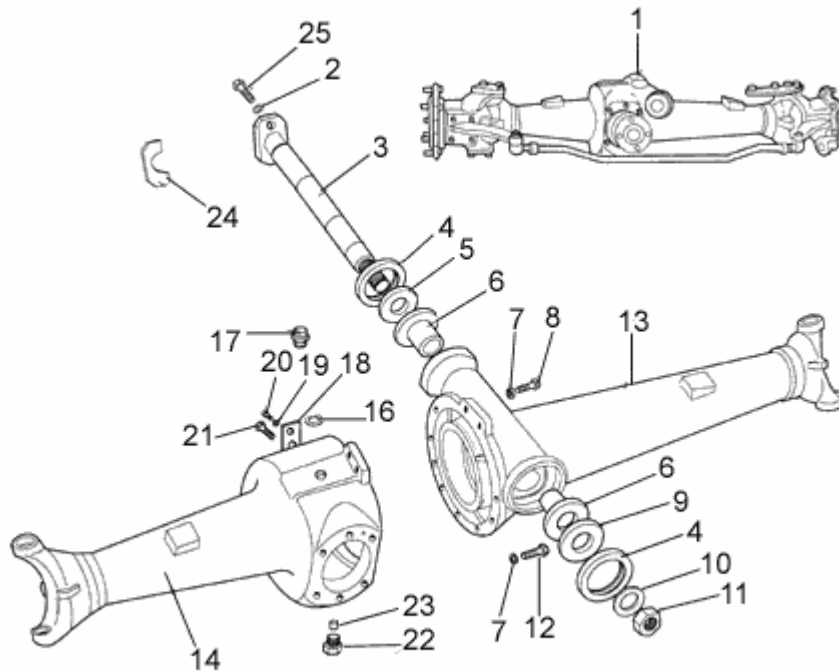

FIGURE	REFERENCE	DENOMINATION	AMOUNT
001	54.00500.20	PUENTE DIRECTRIZ D/T	1
002	104.12000.00	WASHER DIN7980 D12	2
003	15.00527.00	SHAFT CIL/CIL	1
004	202.70085.50	SEAL DIN3760A	2
005	15.00529.00	BUSH	1
006	15.00526.00	BEARING	2
007	104.10000.00	WASHER DIN7980 D10	10
008	604.10045.86	SCREW DIN931	2
009	15.00528.00	BUSH	1
010	104.24000.00	CIR-CLIP EXT. DIN7980	1
011	01.01317.00	NUT	1
012	604.10035.86	SCREW DIN931	8
013	15.00522.01	ASCLE HOUSING	1
014	15.00523.01	ASCLE HOUSING	1
015	701.10000.66	NUT DIN934 M10x1.5	2
016	107.14000.10	WASHER AL 14x20x1.5	3
017	52.00365.00	CAP	1
018	15.00483.00	COVER HANDHOLE	2

TRANSMISSION
REAR AXLE

FIGURE	REFERENCE	DENOMINATION	AMOUNT
019	104.08000.00	WASHER DIN7980 D8	4
020	603.08020.86	SCREW DIN933 M8x20	4
021	15.00484.00	SCREW DIN933*	2
022	00.02803.00	SCREW DIN910*	1
023	01.00335.00	MAGNET	1
024	15.00532.00	GRUESO REG. DISCO	1
024	15.00532.01	GRUESO REG. DISCO	1
025	603.12030.86	SCREW DIN933 M12x30	2

TRANSMISSION

GEAR SUPPORT AND BRAKE REAR AXLE



FIGURE	REFERENCE	DENOMINATION	AMOUNT
001	15.50000.03	CONICAL GEAR SET	1
002	307.40035.00	BEARING DIN720	1
004	307.35033.00	BEARING DIN720	1
005	202.50010.50	SEAL DIN3760	1
006	15.04342.00	WASHER ADJUST.	1
006	15.04343.00	WASHER ADJUST.	1
006	15.04344.00	WASHER ADJUST.	1
007	15.00357.00	STUD DIN939 M12x1,75	6
008	104.12000.66	CIR-CLIP EXT. D12	6
009	701.12000.80	NUT	6
010	43.00430.04	GEAR SUPPORT	1
011	43.04301.00	FLANGE	1
012	43.04302.02	WASHER ADJUST.	1
012	43.04302.04	WASHER ADJUST.	1
012	43.04302.05	WASHER ADJUST.	1
013	104.08000.00	WASHER DIN7980 D8	8
014	603.08030.86	SCREW DIN933 M8X30	8
015	43.00433.01	COUPLING CYL/CYL	1

TRANSMISSION

GEAR SUPPORT AND BRAKE REAR AXLE

FIGURE	REFERENCE	DENOMINATION	AMOUNT
016	201.37003.50	O-RING DIN3770	1
017	15.00368.01	WASHER	1
018	710.20000.66	NUT DIN935 M20x1,5	1
019	401.04040.60	PIN	1

TRANSMISSION

AXLES SHAFT AND LINKAGE SUPPORT REAR AXLE

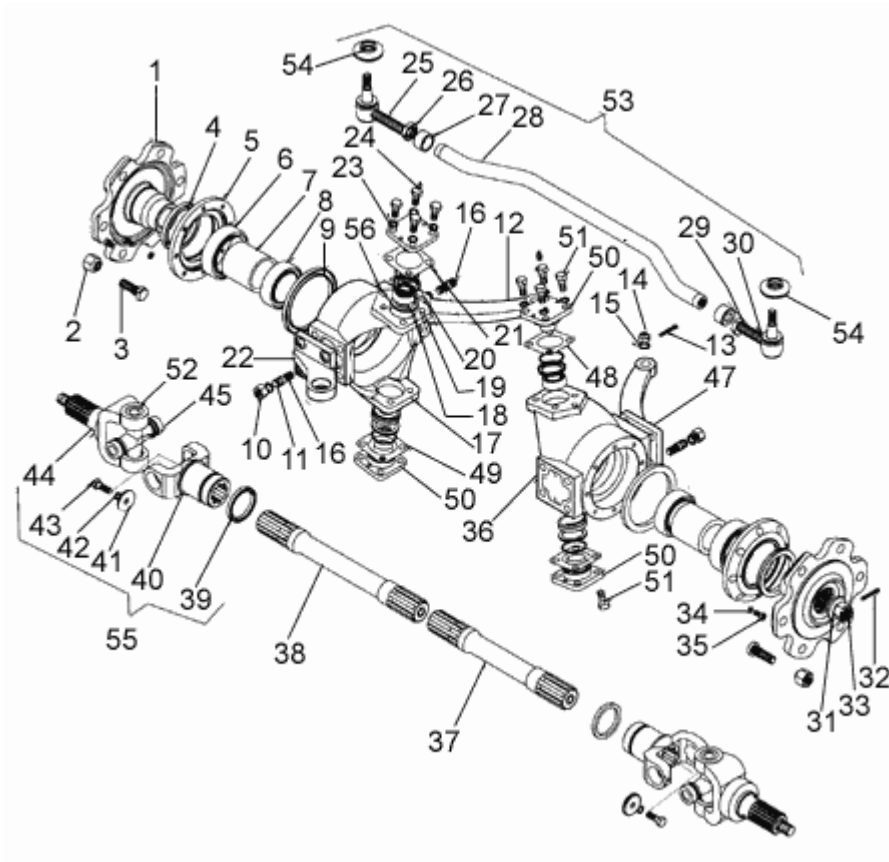

FIGURE	REFERENCE	DENOMINATION	AMOUNT
001	15.00545.00	WHEEL HUB	2
002	15.00453.00	NUT	12
003	15.00452.00	SCREW FASTENING WHEEL	12
004	202.77095.50	SEAL DIN3760	2
005	15.00544.00	HUBCAP	2
006	301.70020.00	BEARING DIN625	2
007	15.00543.00	BUSH	2
008	301.60018.00	BEARING DIN625	2
009	202.72010.50	SEAL DIN3760	2
010	01.01308.00	NUT	16
011	104.14000.00	CIR-CLIP EXT. DIN7980	16
012	15.05401.00	TURNABLE ARM	1
013	401.03025.60	PASADOR DIN94 3,2x18	2
014	711.14000.66	NUT DIN982 M14 8.8 K	2
015	101.14000.66	WASHER DIN125 D14	2
016	00.00587.00	STUD DIN939*	8
017	15.05410.01	ART. FORK	2
018	307.25016.00	BEARING DIN720	4

TRANSMISSION

AXLES SHAFT AND LINKAGE SUPPORT REAR AXLE

FIGURE	REFERENCE	DENOMINATION	AMOUNT
019	15.00564.00	WASHER DIN1441*	4
020	201.41003.50	O-RING DIN3770	4
021	15.05653.00	REGUL SPACER	1
021	15.05654.00	REGUL SPACER	1
022	43.00566.03	SUPPORT ART.	2
023	104.12000.00	WASHER DIN7980 D12	17
024	901.08000.33	GREASER DIN71412-A M8x1,25	5
025	15.01017.00	L BALL	1
026	709.18000.66	NUT	1
027	15.01015.00	BUSH	2
028	15.01014.01	STEERING ROD	1
029	709.18000.66	NUT	1
030	15.01017.00	L BALL	1
031	15.00561.00	WASHER DIN125 20.5x45x5	2
032	401.04040.60	PIN	2
033	710.20000.66	NUT DIN935 M20x1,5	2
034	104.08000.00	WASHER DIN7980 D8	16
035	601.08020.86	SCREW DIN912	16
036	15.05410.01	ART. FORK	1
037	15.00557.01	DRIVE SHAFT	1
038	15.00556.01	DRIVE SHAFT	1
039	202.58010.50	SEAL DIN3760	2
040	43.00558.00	ART. FORK	2
041	43.00559.00	WASHER DIN125*	2
042	104.10000.00	WASHER DIN7980 D10	2
043	01.01208.00	SCREW DIN931*	2
044	15.00560.00	ART. FORK	2
045	15.00555.00	AXLES	2
046	15.05553.00	AGUJA DIN5402	1
047	15.05400.00	TURNABLE ARM	8
048	15.05654.00	REGUL SPACER	1
049	15.05653.00	REGUL SPACER	1
050	15.00567.00	BEARING SUPPORT	4
051	15.00568.00	SCREW DIN931*	12
052	15.00554.00	REGUL SKIM	8
053	15.05070RE01	STEERING ROD	1

TRANSMISSION**AXLES SHAFT AND LINKAGE SUPPORT REAR AXLE**

FIGURE	REFERENCE	DENOMINATION	AMOUNT
054	15.10180.00	GUARD SWIVEL FITTING	2
055	15.05110RE01	PROPELLER SHAFT	2
056	01.03903.00	WASHER ADJUST.	16

TRANSMISSION

DIFFERENTIAL HOUSING AND GEAR REAR AXLE

CHASSIS: 31677

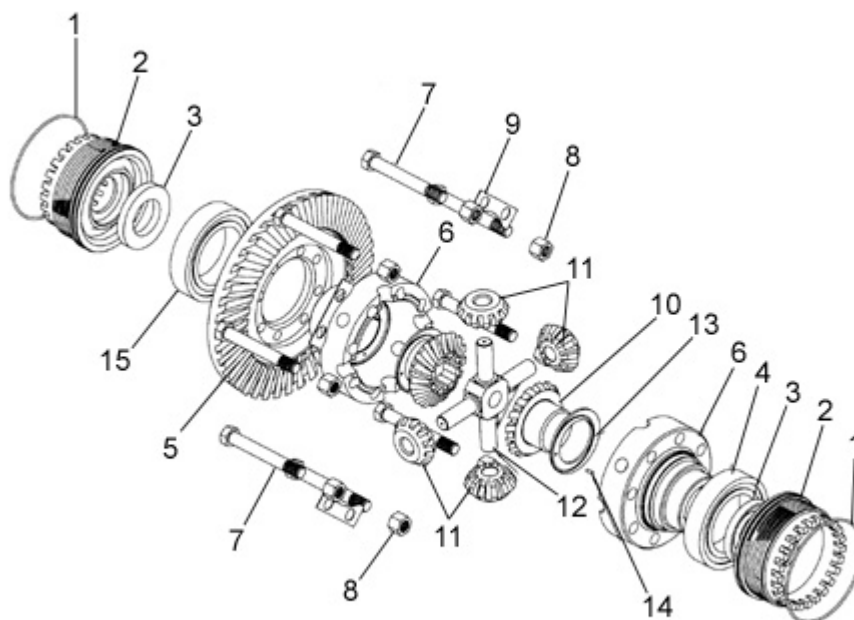

FIGURE	REFERENCE	DENOMINATION	AMOUNT
001	201.12025.50	O-RING DIN3770	2
002	15.00424.01	COVER HANDHOLE	2
003	202.42010.50	SEAL DIN3760	2
004	301.70024.00	BEARING DIN625	1
005	15.50000.03	CONICAL GEAR SET	1
006	15.04100RE00	DIFFERENTIAL HOUSING	1
007	15.00418.00	SCREW DIN931*	8
008	718.14000.80	NUT	8
009	15.00419.00	PANEL	4
010	15.00416.01	GEAR CONICAL	2
011	15.00415.01	GEAR CONICAL	4
012	15.00414.00	AXLES	1
013	15.00411.02	ADJUSTABLE WASHER 52.25x77x3	2
014	403.03010.00	PIN DIN6325 3x10	2
015	303.70024.00	BEARING DIN628 7214-B	1

TRANSMISSION STEERING CYLINDER REAR AXLE

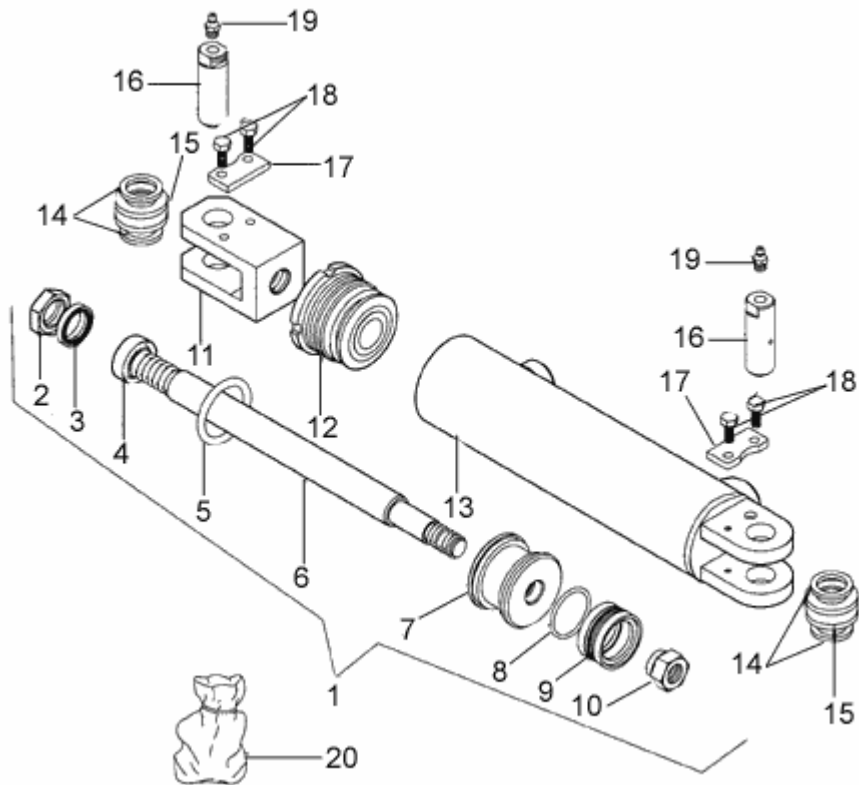

FIGURE	REFERENCE	DENOMINATION	AMOUNT
001	15.01050.02	CYLINDER D/E	1
002	709.20000.66	NUT	1
003	228.02230.50	WIPER RING	1
004	229.02228.50	GASKET DIN6505	1
005	201.04705.50	O-RING DIN3770	1
006	15.01053.02	SPINDLE	1
007	19.00221.01	PISTON	1
008	201.01725.50	O-RING DIN3770	1
009	207.05543.50	JUNTA DSP 55X43	1
010	718.16000.66	NUT	1
011	43.50621.00	CYLINDER ROD HEAD	1
012	19.00220.02	GUIA VASTAGO 22x55x59,5	1
013	15.01022.02	CUERPO CIL. D55x298 SOLD.	1
014	10.00684.00	WASHER DIN126*	4
015	913.20012.00	BUSHING	2
016	31.00622.00	SHAFT CIL/COA	2
017	15.00832.00	PANEL	2
018	603.06015.86	SCREW DIN933 M6x15	2

TRANSMISSION

STEERING CYLINDER REAR AXLE

FIGURE	REFERENCE	DENOMINATION	AMOUNT
019	901.08000.33	GREASER DIN71412-A M8x1,25	2
020	15.99100.01	GASKET SET	1

TRANSMISSION CARDAN JOINTS RM

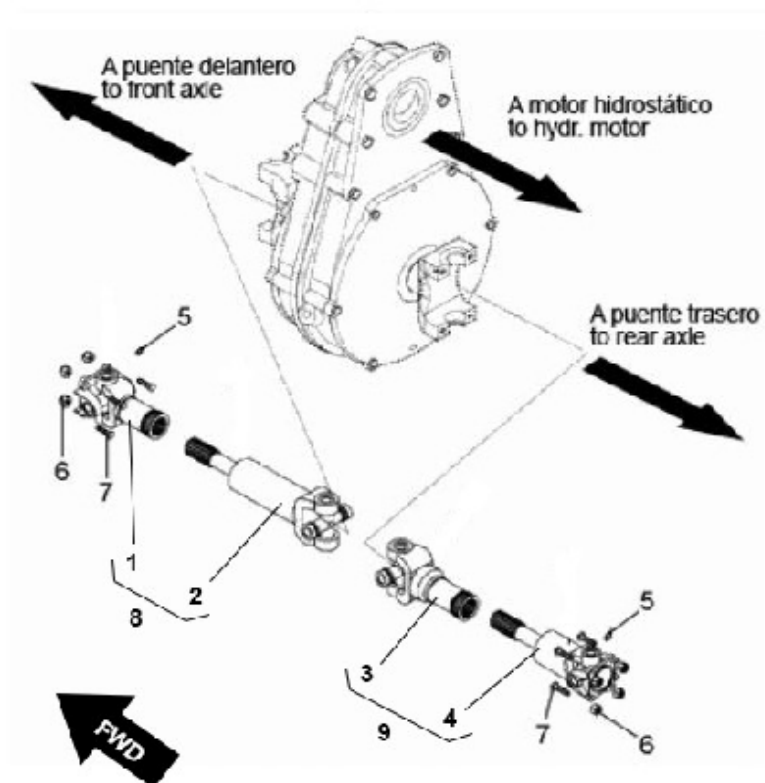

FIGURE	REFERENCE	DENOMINATION	AMOUNT
001	43.00590.00	PROPELLER SHAFT	1
002	55.00482.00	PROPELLER SHAFT	1
003	15.00481.00	CARDAN JOINTS FEMALE	1
004	15.00482.00	NSS	1
005	901.08000.33	GREASER DIN71412-A M8x1,25	4
006	722.11000.80	NUT	8
007	15.00457.02	SCREW DIN931*	8
008	15.03361.00	CARDAN JOINT 520 SERIE 1350	1
009	15.03362.00	CARDAN JOINT 290 SERIE 1350	1

COMMENTS

MOD.3920

TRANSMISSION CARDAN JOINT COMPEN

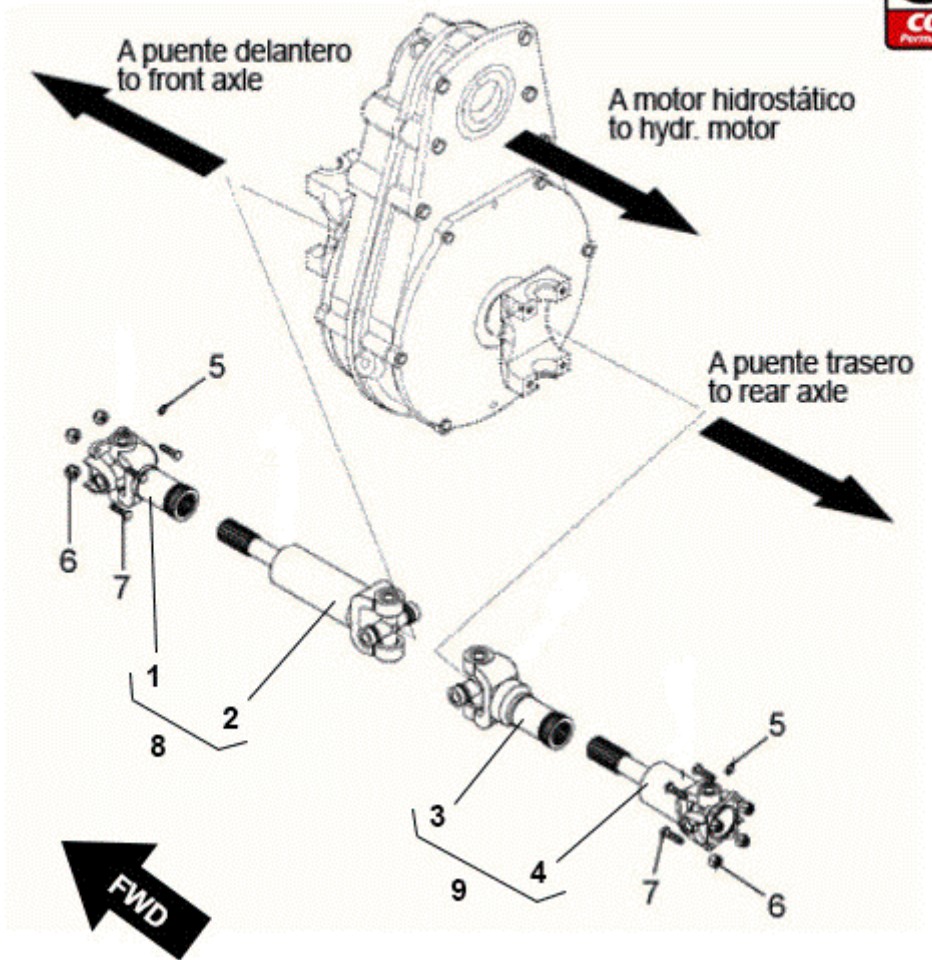

FIGURE	REFERENCE	DENOMINATION	AMOUNT
001	15.00481.00	CARDAN JOINTS FEMALE	1
002	55.00482.01	PROPELLER SHAFT 92x378 MAC.	1
003	15.04812.00	PROPELLER SHAFT 70x151 HEM.	1
004	43.00582.01	PROPELLER SHAFT 40x256 MAC.	1
005	901.08000.33	GREASER DIN71412-A M8x1,25	4
006	722.11000.80	NUT	8
007	15.00457.02	SCREW DIN931*	8
008	15.03365.00	JOINT 446 SERIE 1350	1
009	15.03364.00	JOINT 286 SERIE 1350	1

COMMENTS

MOD.3920

04. CHASSIS

CHASSIS

CHASSIS: 44745

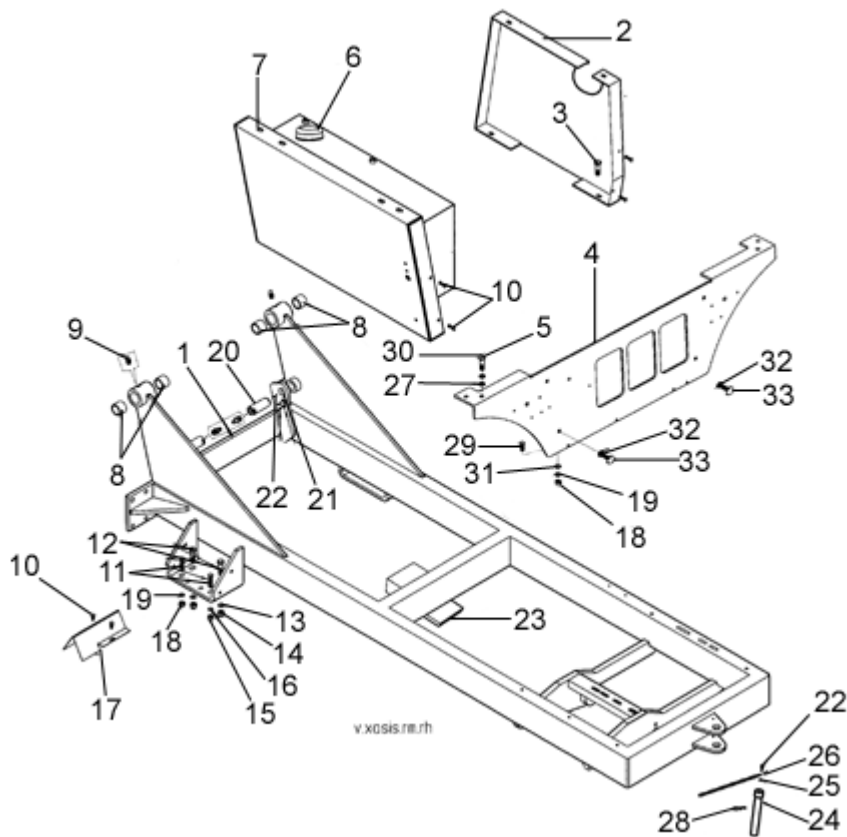

FIGURE	REFERENCE	DENOMINATION	AMOUNT
001	15.00800.12	FRAME	1
002	15.10729.01	SOP. PLAN. REC. 50x392x610	1
003	605.10024.66	SCREW DIN603	5
004	15.00724RE00	ENGINE GUARD	1
005	603.12030.86	SCREW DIN933 M12x30	1
006	15.01524.00	TANK CAP	1
007	15.10728.02	TANK	1
008	15.08141.00	BEARING	4
009	901.08000.33	GREASER DIN71412-A M8x1,25	4
010	603.08015.86	SCREW DIN933 M8x15	4
011	604.14060.86	SCREW DIN931	2
012	604.16060.86	SCREW DIN931	2
013	104.16000.00	CIR-CLIP EXT. DIN7980	2
014	711.16000.66	NUT DIN982 M16 8.8 K	2
015	711.14000.66	NUT DIN982 M14 8.8 K	2
016	104.14000.00	CIR-CLIP EXT. DIN7980	2
017	60.00784.00	GUARD TUBE	2
018	701.08000.66	NUT DIN934 M8X1,25	7

04. CHASSIS

CHASSIS

CHASSIS: 44745

FIGURE	REFERENCE	DENOMINATION	AMOUNT
019	104.08000.00	WASHER DIN7980 D8	7
020	15.04221.00	EJE CIL/CIL 30X50X99	2
021	15.00832.00	PANEL	2
022	603.06015.66	SCREW DIN933	5
023	55.00853.01	TUBE GUIDE SUPPORT	1
024	15.00835.00	AXLE CPA/GRA 25x30x135	1
025	104.06000.00	WASHER DIN7980 D6	1
026	15.00834.00	CHAIN	1
027	101.12000.66	WASHER DIN125 D12	4
028	15.00836.00	PIN DIN11024 R4	1
029	603.08035.86	SCREW DIN933	3
030	104.12000.00	WASHER DIN7980 D12	4
031	101.12000.66	WASHER DIN125 D12	4
032	104.10000.00	WASHER DIN7980 D10	4
033	605.10024.66	SCREW DIN603	4

05. BRAKE ACTIVATION FOOT BRAKE

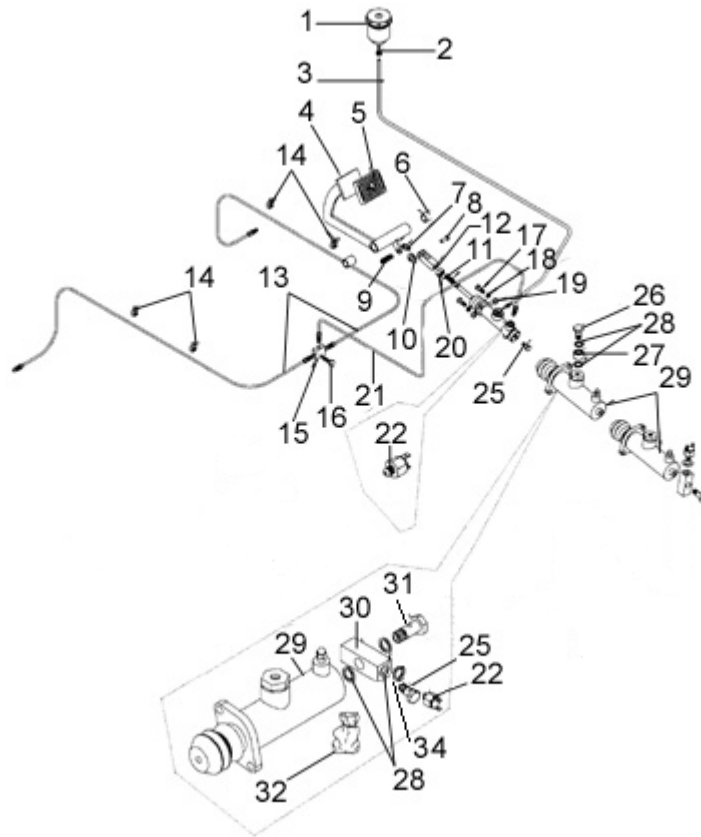

FIGURE	REFERENCE	DENOMINATION	AMOUNT
001	43.00751.01	BRAKING LIQUID TANK	1
002	912.09000.66	CLAMP	2
003	43.00750.06	TUBO PLAS. TRANS. 6x9x850	1
004	15.10740.00	BRAKE PEDAL	1
005	43.07310.01	PANEL	2
006	923.18030.00	BEARING	1
007	901.08000.33	GREASER DIN71412-A M8x1,25	1
008	01.00514.01	AXLE CIL/CPA 14x8x28	1
009	01.00223.00	SPRING TENSION	1
010	101.08000.66	WASHER DIN125 D8	1
011	43.00576.11	ROD STRAIGHT R7/16	1
012	01.00564.01	ART. FORK	1
013	55.07774.00	TUBE BUNDY6	2
014	929.05000.00	TUBE GUIDE SUPPORT	4
015	55.00756.00	NIPPLE H/H/H	1
016	604.06035.86	SCREW DIN931 M6x35	2
017	604.08025.86	SCREW DIN931	2
018	104.08000.00	WASHER DIN7980 D8	2

05. BRAKE ACTIVATION

FOOT BRAKE

FIGURE	REFERENCE	DENOMINATION	AMOUNT
019	711.08000.86	NUT	2
020	01.01304.00	NUT	1
021	55.07773.00	TUBE BUNDY6	1
022	43.01521.00	SWITCH	1
025	80.01090.00	CAP	1
026	55.00760.00	NIPPLE SCREW SIM.	1
027	55.00759.00	NIPPLE O/TB	1
028	106.12000.20	WASHER CU	2
029	55.00770.20	BRAKE PUMP	1
030	55.00758.00	NIPPLE	1
031	55.00757.20	NIPPLE SCREW SIM.	1
032	55.00770.03	GASKET SET	1
034	107.10000.10	WASHER AL	1

05. BRAKE ACTIVATION

FOOT BRAKE

CHASSIS: 69609

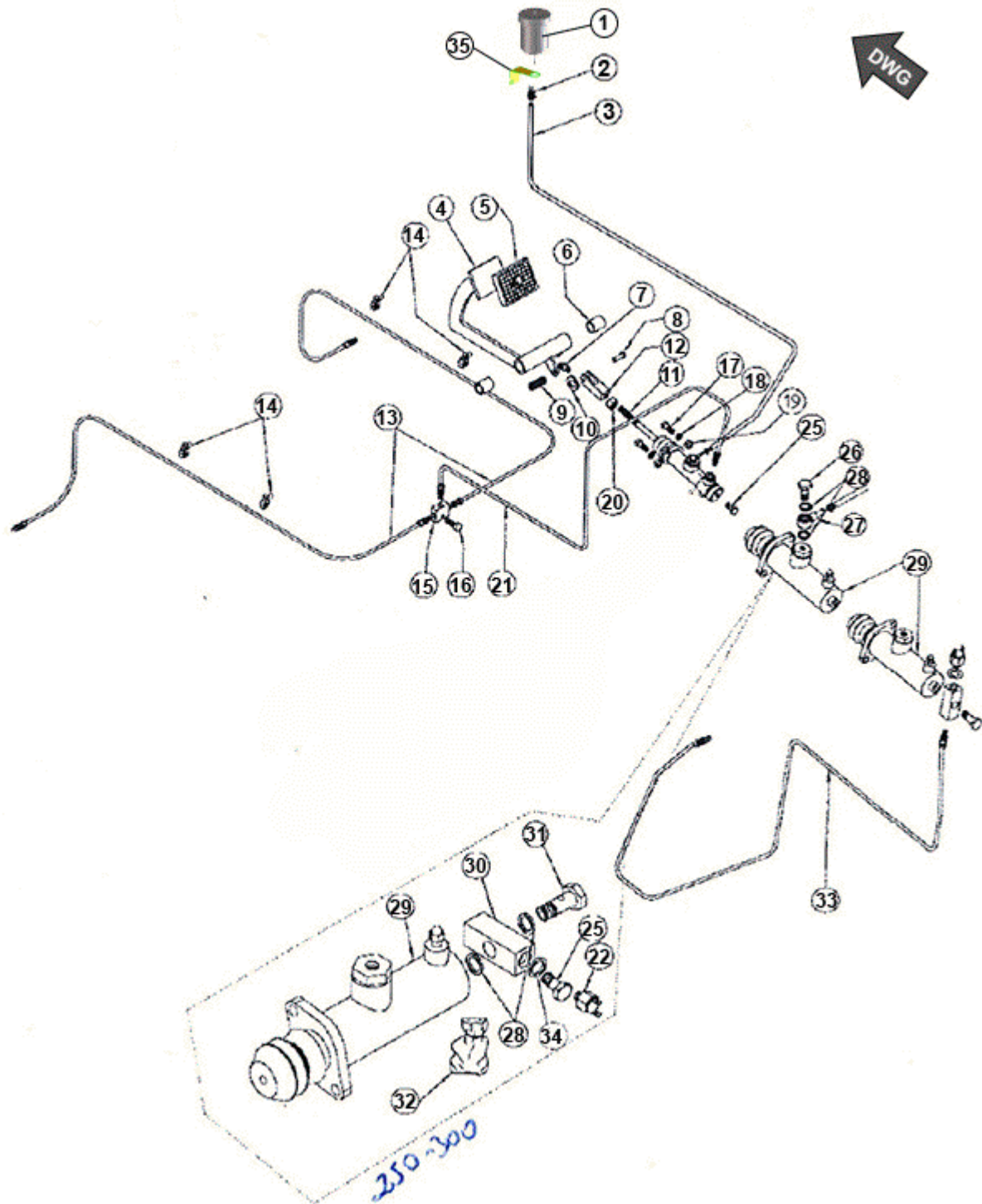

FIGURE	REFERENCE	DENOMINATION	AMOUNT
001	43.00751.02	TANK SET	1
002	912.09000.66	CLAMP	2
003	43.00750.06	TUBO PLAS. TRANS. 6x9x850	1
004	15.10740.00	BRAKE PEDAL	1
005	43.07310.01	PANEL	2

006	923.18030.00	BEARING	1
007	901.08000.33	GREASER DIN71412-A M8x1,25	1
008	01.00514.01	AXLE CIL/CPA 14x8x28	1
009	01.00223.00	SPRING TENSION	1
010	101.08000.66	WASHER DIN125 D8	1
011	43.00576.11	ROD STRAIGHT R7/16	1
012	01.00564.01	ART. FORK	1
013	55.07774.00	TUBE BUNDY6	2
014	929.05000.00	TUBE GUIDE SUPPORT	4
015	55.00756.00	NIPPLE H/H/H	1
016	604.06035.86	SCREW DIN931 M6x35	2
017	604.08025.86	SCREW DIN931	2
018	104.08000.00	WASHER DIN7980 D8	2
019	711.08000.86	NUT	2
020	01.01304.00	NUT	1
021	55.07773.00	TUBE BUNDY6	1
022	43.01521.00	SWITCH	1
025	80.01090.00	CAP	1
026	55.00760.00	NIPPLE SCREW SIM.	1
027	55.00759.00	NIPPLE O/TB	1
028	106.12000.20	WASHER CU	2
029	55.00770.20	BRAKE PUMP	1
030	55.00758.00	NIPPLE	1
031	55.00757.20	NIPPLE SCREW SIM.	1
032	55.00770.03	GASKET SET	1
034	107.10000.10	WASHER AL	1
035	43.07511.00	TANK BRAKE SUPPORT	1

COMMENTS

MOD.4254

05. BRAKE ACTIVATION HANDBRAKE

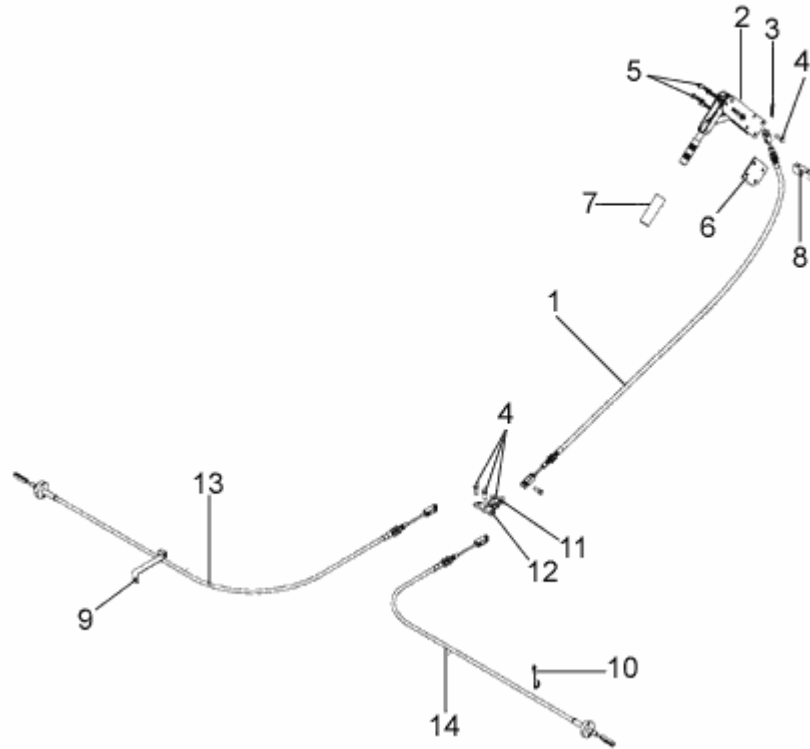

FIGURE	REFERENCE	DENOMINATION	AMOUNT
001	60.00708.00	BRAKE CABLE 250RM-300RM	1
002	43.00755.01	CONTROL LEVER	1
003	401.02025.60	PIN DIN94 2x25	1
004	01.00514.02	AXLE CIL/CPA	4
005	604.08045.86	SCREW DIN931 M8x45	4
006	15.11723.00	GRUESO REG. REC. 4x68x80	1
007	43.07550RE01	BRAKE	1
008	43.00755.11	STRIP SUPPORT	1
009	15.12800.00	CLAMP TAPE	1
009	830.01808.00	CLAMP LOOP	1
010	09.00715.00	SOP. GUIA 4X22X83 CABLE FRENO	1
011	43.00765.00	DOUBLE FORK	1
012	43.00766.00	STRIP SUPPORT	1
013	44.00706.02	BRAKE CABLE	1
014	43.00706.01	BRAKE CABLE D3.5X1215	1

05. BRAKE ACTIVATION

BRAKE



FIGURE	REFERENCE	DENOMINATION	AMOUNT
001	15.00403.10	DISK BRAKE	2
002	15.00470.00	CASING	1
003	15.00469.00	DISK BRAKE	4
004	15.00473.00	DISK BRAKE	4
005	202.14412.50	SEAL DIN3760	1
006	15.00467.00	DISK BRAKE	1
007	15.00466.00	PISTON	1
008	15.00465.00	BRAKE PLATE	1
009	15.00472.00	SPRING COMPRESSION	6
010	15.00471.00	SCREW DIN931*	12
011	106.10000.20	WASHER CU 10x16x1,5 DIN7603A	12
012	201.19004.50	O-RING DIN3770	1
013	201.21004.50	O-RING DIN3770	1
014	201.28703.50	O-RING DIN3770	1
015	15.00475.01	AXLE CIL/COR	3
016	201.05025.50	O-RING DIN3770	3
017	52.00365.00	CAP	1

018	43.00408.41	SCREW DIN564*	1
019	45.00408.41	CAP	1
020	80.01035.01	CAP	2
020	10.00921.00	CAP M14X150 DIN908	1
021	107.14000.10	WASHER AL 14x20x1.5	3
022	201.11503.50	O-RING DIN3770	1
023	701.08000.86	NUT	3
024	15.00476.00	STUD M10x47	8
025	104.10000.00	WASHER DIN7980 D10	8
026	711.10000.66	SHOCK ABSORBER	8
027	43.99403.00	GASKET SET	1
028	622.08025.86	SCREW DIN916	3
029	10.00921.00	CAP M14X150 DIN908	1

STEERING

STEERING

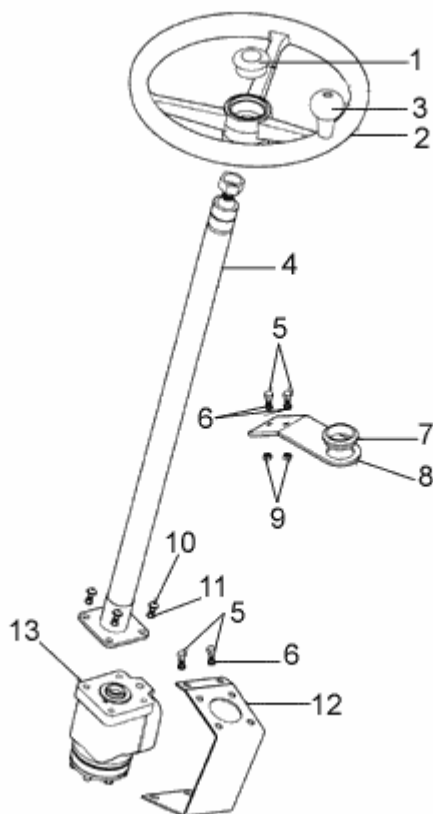

FIGURE	REFERENCE	DENOMINATION	AMOUNT
001	00.00626.03	TRIM	1
002	15.01016.01	STEERING WHEEL D21-315 WITH POMMEL	1
003	15.10160.01	KNOB	1
004	55.10680.00	STEERING COLUMM	1
005	603.08020.86	SCREW DIN933 M8x20	4
006	104.08000.00	WASHER DIN7980 D8	4
007	15.20727.00	NYLON BEARING 16x38x52	1
008	15.20725.00	STEERING SUPPORT	1
009	701.08000.66	NUT DIN934 M8X1,25	4
010	630.10025.96	SCREW ISO7380	4
011	104.10000.00	WASHER DIN7980 D10	4
012	15.20726.00	STEERING SUPPORT	1
013	31.00613.00	STEERING VALVE	1

STEERING

STEERING

CHASSIS: 63368

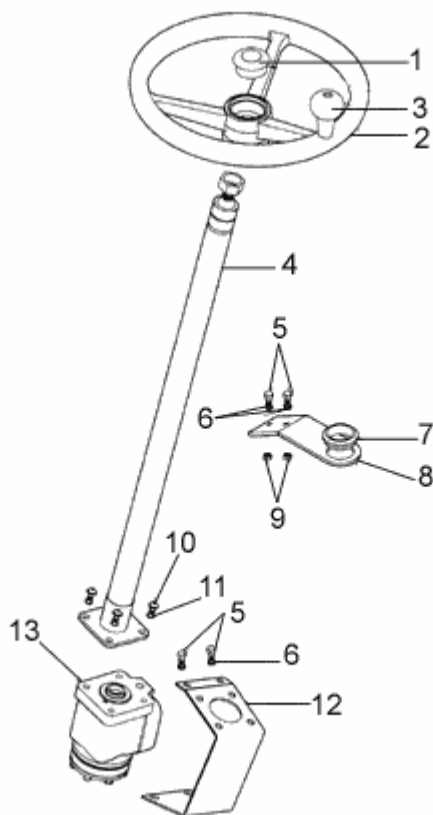

FIGURE	REFERENCE	DENOMINATION	AMOUNT
002	15.01016.01	STEERING WHEEL D21-315 WITH POMMEL	1
003	15.10160.01	KNOB	1
004	55.10680.00	STEERING COLUMN	1
005	603.08020.86	SCREW DIN933 M8x20	4
006	104.08000.00	WASHER DIN7980 D8	4
007	15.20727.00	NYLON BEARING 16x38x52	1
008	15.20725.00	STEERING SUPPORT	1
009	701.08000.66	NUT DIN934 M8X1,25	4
010	630.10025.96	SCREW ISO7380	4
011	104.10000.00	WASHER DIN7980 D10	4
012	15.20726.00	STEERING SUPPORT	1
013	31.00613.00	STEERING VALVE	1

STEERING
STEERING
CHASSIS: 79164

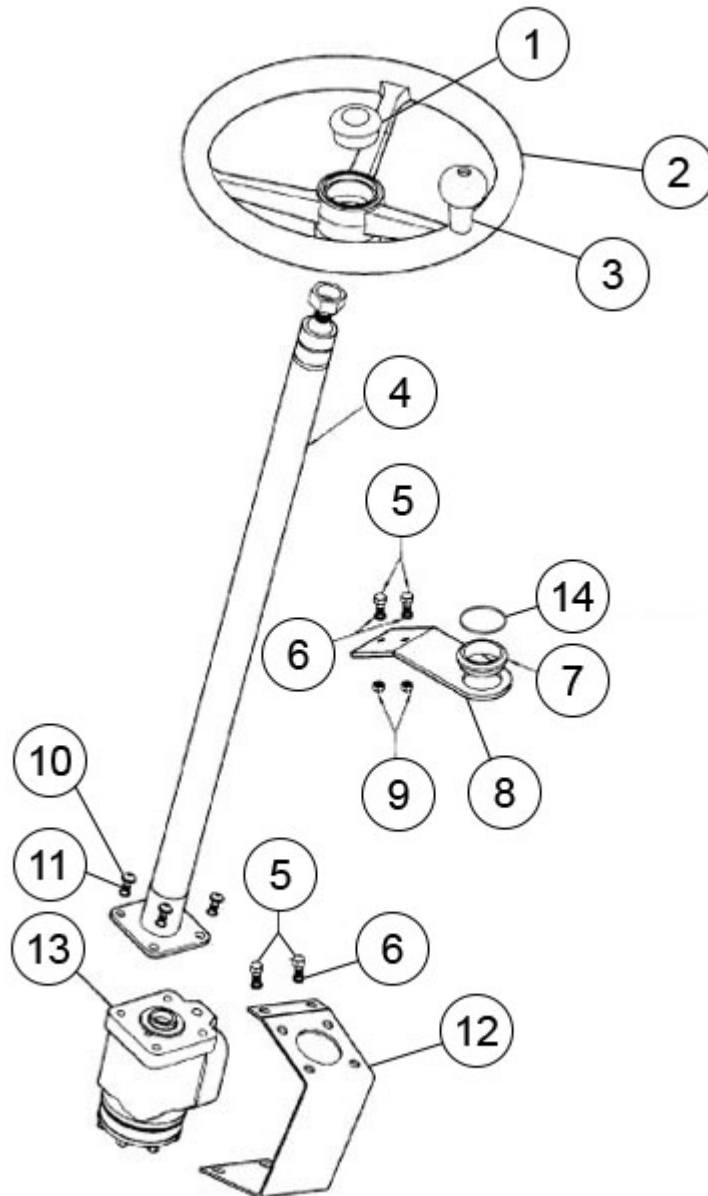

FIGURE	REFERENCE	DENOMINATION	AMOUNT
001	00.00626.05	TRIM	1
002	15.01016.01	STEERING WHEEL D21-315 WITH POMMEL	1
003	15.10160.01	KNOB	1
004	55.10680.00	STEERING COLUMM	1
005	603.08020.86	SCREW DIN933 M8x20	4
006	104.08000.00	WASHER DIN7980 D8	4
007	15.20727.01	NYLON BEARING 17X38X52	1
008	15.20725.00	STEERING SUPPORT	1
009	701.08000.66	NUT DIN934 M8X1,25	4
010	630.10025.96	SCREW ISO7380	4

011	104.10000.00	WASHER DIN7980 D10	4
012	15.20726.00	STEERING SUPPORT	1
013	31.00613.00	STEERING VALVE	1
014	55.90620.01	CONMUTATOR	1
015	201.03953.50	O-RING DIN3770 D39.5XD3	1

WHEEL WHEELS

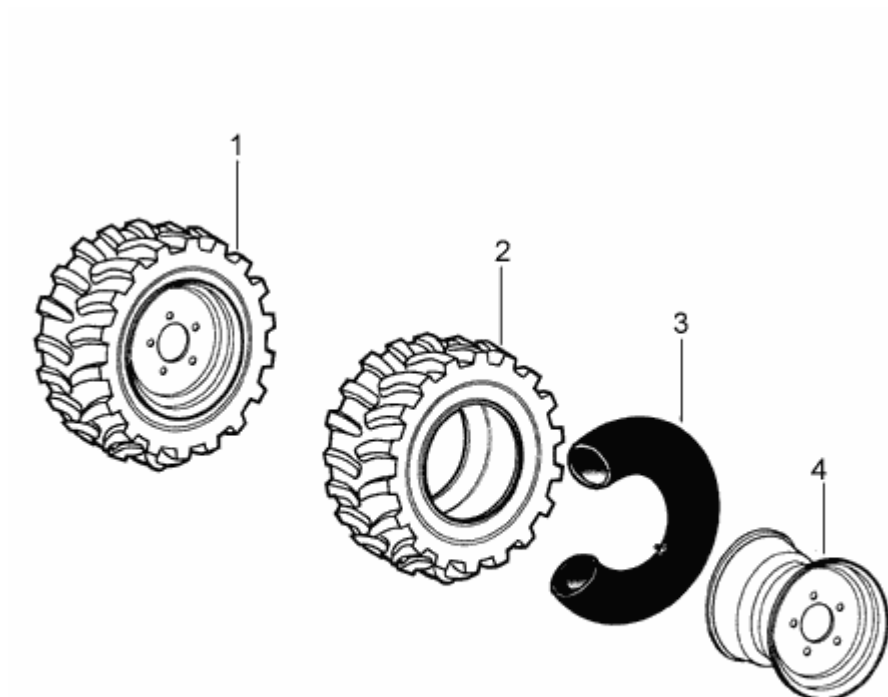

FIGURE	REFERENCE	DENOMINATION	AMOUNT
001	15.00901DE05	WHEEL RIM	2
001	15.00901IZ05	WHEEL RIM	2
002	16.00913.02	AT TYRE 10.0/75-15.3 x 10P	4
003	15.00912.01	TUBE	4
004	43.00911.00	WHEEL RIM	4

WHEEL

WHEELS

CHASSIS: 58956

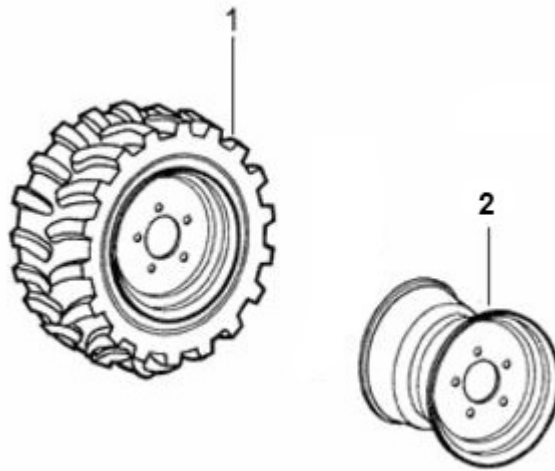

FIGURE	REFERENCE	DENOMINATION	AMOUNT
001L	15.00901IZ06	WHEEL ASSY 10.0/75-13,3 14PR	1
001R	15.00901DE06	WHEEL ASSY 10.0/75-15,3 14PR	1
002	43.00911.00	WHEEL RIM	1

COMMENTS

MOD.3688

BODY

FLOOR

CHASSIS: 44745

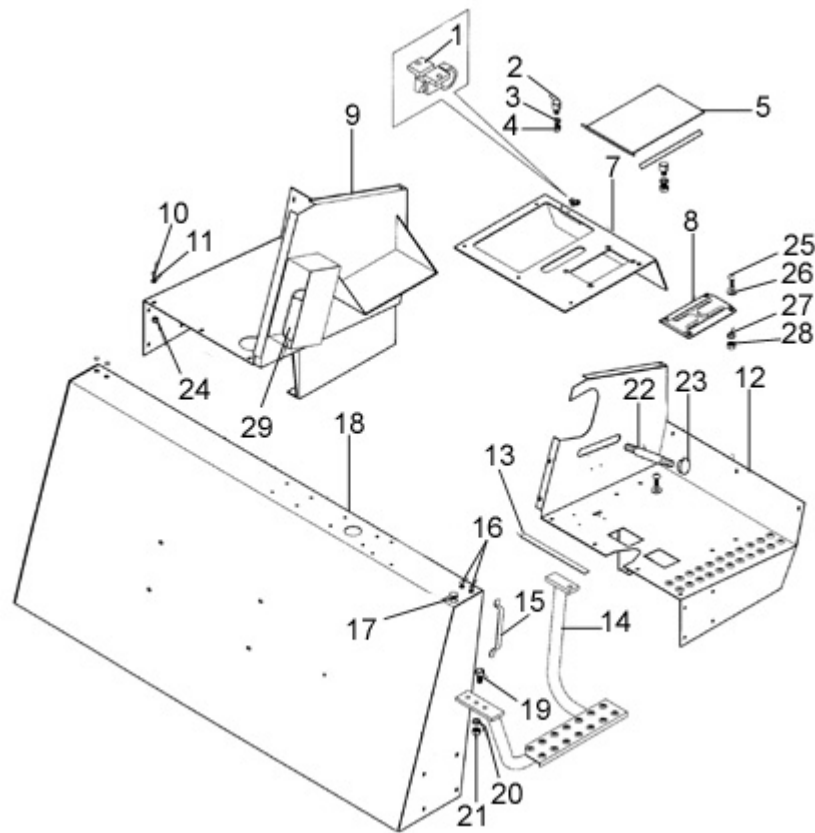

FIGURE	REFERENCE	DENOMINATION	AMOUNT
001	01.01925.00	LATCH	1
002	01.00735.00	SUPPORT ART.	2
003	104.08000.00	WASHER DIN7980 D8	2
004	701.08000.66	NUT DIN934 M8X1,25	2
005	15.10733.02	COVER HANDHOLE	2
006	472.04015.00	RUBBER PROFILE MAT.	1
007	15.10735.02	COVER	2
008	40.00930.00	SUPPORT PLATE	2
009	15.10722.02	PLATE	2
010	605.08025.96	SCREW	1
011	104.08000.00	WASHER DIN7980 D8	1
012	15.11722.01	PLATE	1
013	45.00152.00	TOPE. 3x20x280 GOMA	1
014	15.10730.00	HANGER	1
015	46.09991.00	KNOB	6
016	02.32016.00	CAP	6
017	02.32022.00	CAP	6
018	15.10725.01	MAST	4

BODY**FLOOR**

CHASSIS: 44745

FIGURE	REFERENCE	DENOMINATION	AMOUNT
019	603.10030.86	SCREW DIN933	4
020	104.10000.00	WASHER DIN7980 D10	4
021	701.10000.66	NUT DIN934 M10x1.5	1
022	15.01579.00	STUD DIN939	1
023	01.00325.01	KNOB	12
024	727.08004.86	NUT	1
025	630.05020.96	SCREW ISO7380	4
026	101.06000.66	WASHER DIN125 D6	4
027	112.06000.66	WASHER DIN9021 D6	4
028	711.05000.66	NUT DIN982 M5	4
029	01.00036.02	TOOLS-BAG	1

BODY PROTECTORS

CHASSIS: 45648

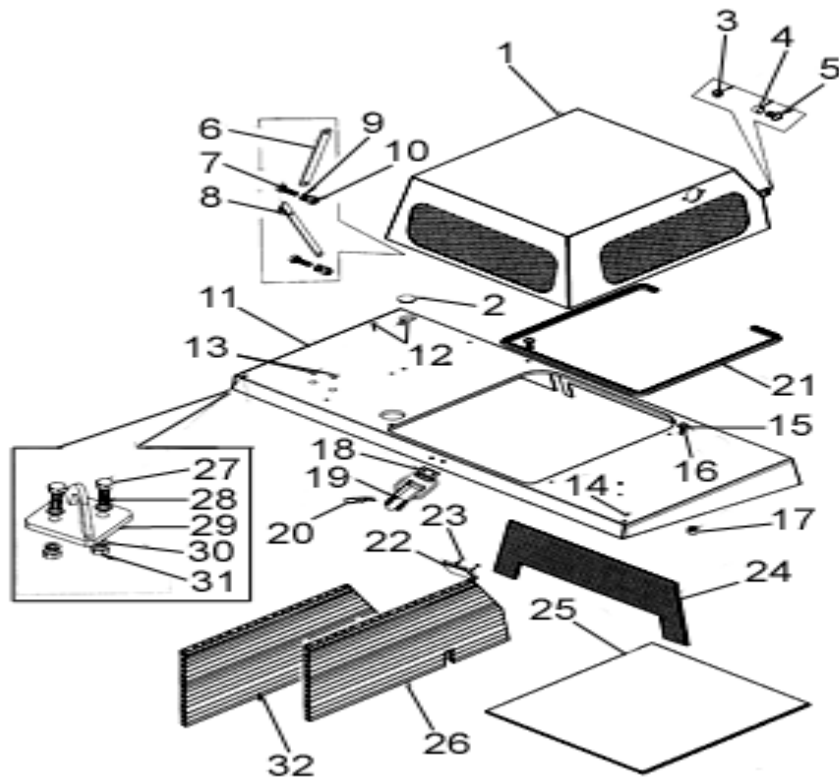

FIGURE	REFERENCE	DENOMINATION	AMOUNT
001	15.10737.04	PROT. MOTOR 270x630x695 Isuzu	1
002	43.70050.00	CAP	2
003	711.10000.66	SHOCK ABSORBER	2
004	43.00758.02	BUSH	2
005	630.10025.96	SCREW ISO7380	2
006	62.21532.00	TIE ROD 4x15x150	1
007	630.06015.96	SCREW ISO7380 M6x15	2
008	62.21531.00	TIE ROD 4x15x177	1
009	101.06000.66	WASHER DIN125 D6	2
010	711.06000.66	NUT DIN982 M6	2
011	15.10723.01	MUDGUARD	1
012	02.23013.00	TAPON. D14	2
013	02.32013.00	CAP	2
014	02.23016.00	CAP	2
015	603.10025.86	SCREW DIN933 M10x25	6
016	01.00837.00	CIR-CLIP INT. DIN9021*	6
017	701.10000.66	NUT DIN934 M10x1.5	6
018	60.01924.01	LATCH	1

**BODY
PROTECTORS**
CHASSIS: 45648

FIGURE	REFERENCE	DENOMINATION	AMOUNT
019	60.01925.01	LATCH	1
020	15.00836.00	PIN DIN11024 R4	1
021	15.11731.01	PERFIL GOMA 16x23x2050	1
022	14.40901.00	RED REFLECTOR	2
023	701.05000.66	NUT DIN934 M5x0.8	4
024	55.11700.00	AMORTIGUADOR. 30x255x607 ESPUM	1
025	55.11702.00	AMORTIGUADOR. 30x530x570 ESPUM	1
026	55.11701.00	AMORTIGUADOR. 30x253x680 ESPUM	1
027	603.12045.86	SCREW DIN933	4
028	101.12000.66	WASHER DIN125 D12	4
029	15.10629.00	BRACKET ANG.	2
030	104.12000.00	WASHER DIN7980 D12	4
031	701.12000.66	NUT DIN934 M12x1.75	4
032	55.11703.00	ABSORBENTE ACUSTICO 255X634X67	1

BODY PROTECTORS

CHASSIS: 67306

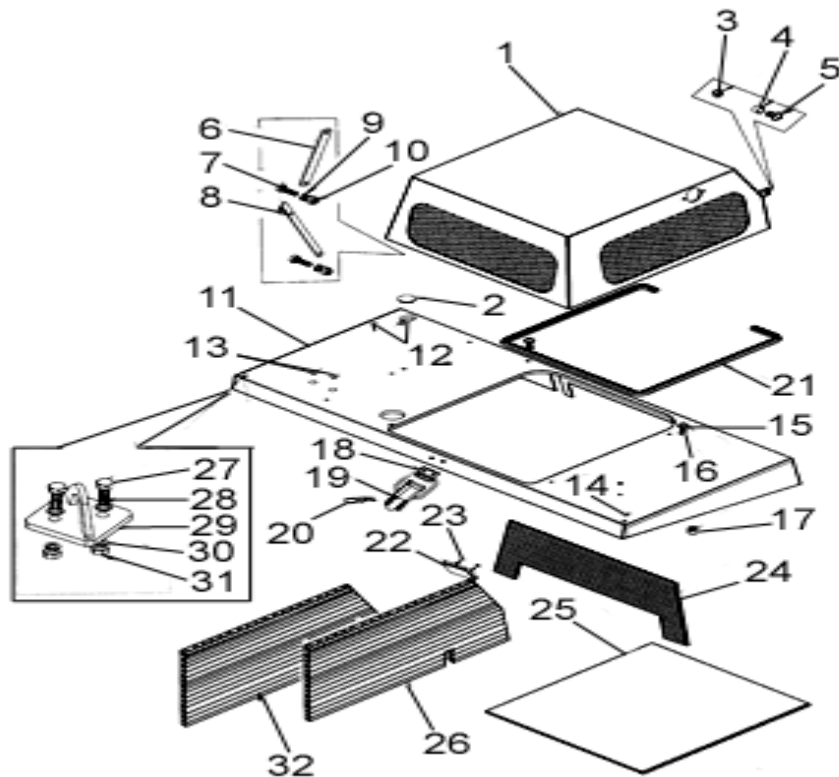

FIGURE	REFERENCE	DENOMINATION	AMOUNT
001	15.10737.04	PROT. MOTOR 270x630x695 Isuzu	1
002	43.70050.00	CAP	2
003	711.10000.66	SHOCK ABSORBER	2
004	43.00758.02	BUSH	2
005	630.10025.96	SCREW ISO7380	2
006	62.21532.00	TIE ROD 4x15x150	1
007	630.06015.96	SCREW ISO7380 M6x15	2
008	62.21531.00	TIE ROD 4x15x177	1
009	101.06000.66	WASHER DIN125 D6	2
010	711.06000.66	NUT DIN982 M6	2
011	15.10723.01	MUDGUARD	1
012	02.23013.00	TAPON. D14	2
013	02.32013.00	CAP	2
014	02.23016.00	CAP	2
015	603.10025.86	SCREW DIN933 M10x25	6
016	01.00837.00	CIR-CLIP INT. DIN9021*	6
017	701.10000.66	NUT DIN934 M10x1.5	6
018	60.01924.01	LATCH	1

**BODY
PROTECTORS**
CHASSIS: 67306

FIGURE	REFERENCE	DENOMINATION	AMOUNT
019	70.08026.00	ENGINE COVER LOCKING	1
020	15.00836.00	PIN DIN11024 R4	1
021	15.11731.01	PERFIL GOMA 16x23x2050	1
022	14.40901.00	RED REFLECTOR	2
023	701.05000.66	NUT DIN934 M5x0.8	4
024	55.11700.00	AMORTIGUADOR. 30x255x607 ESPUM	1
025	55.11702.00	AMORTIGUADOR. 30x530x570 ESPUM	1
026	55.11701.00	AMORTIGUADOR. 30x253x680 ESPUM	1
027	603.12045.86	SCREW DIN933	4
028	101.12000.66	WASHER DIN125 D12	4
029	15.10629.00	BRACKET ANG.	2
030	104.12000.00	WASHER DIN7980 D12	4
031	701.12000.66	NUT DIN934 M12x1.75	4
032	55.11703.00	ABSORBENTE ACUSTICO 255X634X67	1

BODY

SEAT

CHASSIS: 30339



FIGURE	REFERENCE	DENOMINATION	AMOUNT
001	01.00706.07	DRIVER S SEAT	1
002	605.10030.66	SCREW DIN603	4
003	104.10000.00	WASHER DIN7980 D10	4
004	701.10000.66	NUT DIN934 M10x1.5	4
005	711.10000.66	SHOCK ABSORBER	4
006	45.60002.01	BELT	1

MACHINE WORK HOPPER

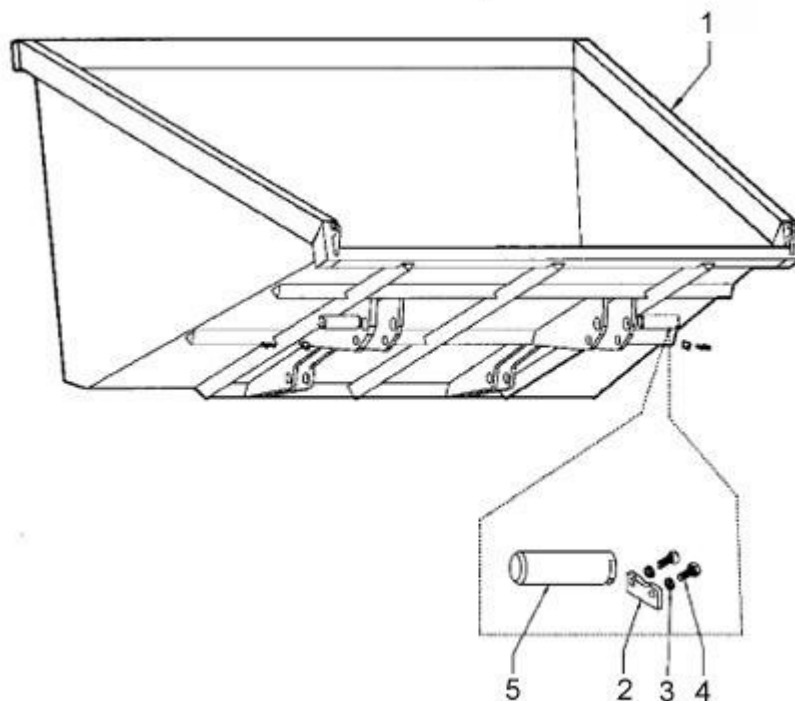

FIGURE	REFERENCE	DENOMINATION	AMOUNT
001	15.00830.21	SKIP	1
002	15.00832.00	PANEL	2
003	104.06000.00	WASHER DIN7980 D6	4
004	603.06015.86	SCREW DIN933 M6x15	4
005	15.00831.00	SHAFT CIL/COA	2

MACHINE WORK

DUMPING CYLINDER

CHASSIS: 43608

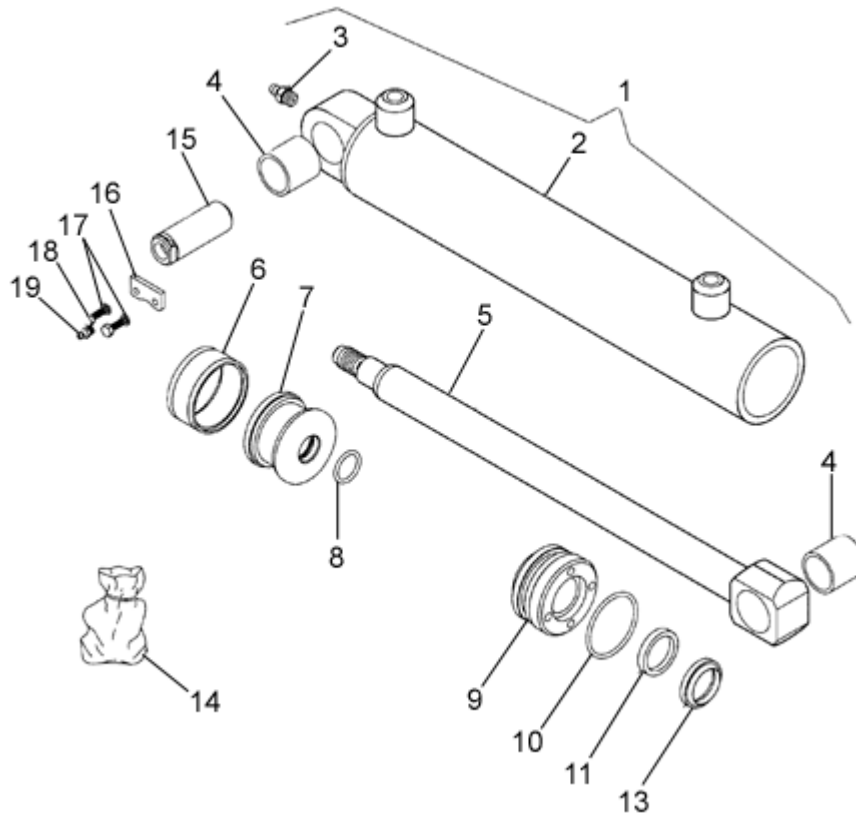

FIGURE	REFERENCE	DENOMINATION	AMOUNT
001	08.00500.09	CYLINDER D/E	2
002	08.00520.13	CUERPO CIL. 63X456	2
003	901.08000.33	GREASER DIN71412-A M8x1,25	2
004	949.03035.00	CASQUILLO. 30X34X35 DIN 1494	4
005	08.00525.13	VASTAGO D30X464(YBC3032AM)	2
006	207.63031.50	JUNTA ESTAN. COMPAC. 63X47X31	2
007	08.00521.09	EMBOLO 24X63X42	2
008	201.03003.50	JUNTA DIN3770 D30X3	2
009	08.00528.02	GUIDE	2
010	201.58035.50	JUNTA DIN3770 58X3.5	2
011	217.03040.50	JUNTA DIN6505 30X40X7.3	2
012	08.00530.01	NUT	2
013	228.30038.50	RASCADOR 30X38X5 DOBLE LABIO	2
014	08.99500re09	JUEGO JUNTAS CIL. ELEVACION	2
015	15.01216.00	SHAFT CIL/COA	2
016	15.00832.00	PANEL	2
017	104.06000.00	WASHER DIN7980 D6	4
018	603.06015.86	SCREW DIN933 M6x15	4

MACHINE WORK**DUMPING CYLINDER**

CHASSIS: 43608

FIGURE	REFERENCE	DENOMINATION	AMOUNT
019	903.08000.33	GREASER DIN71412-B	2

10. HYDRAULIC INSTALLATION WORKING

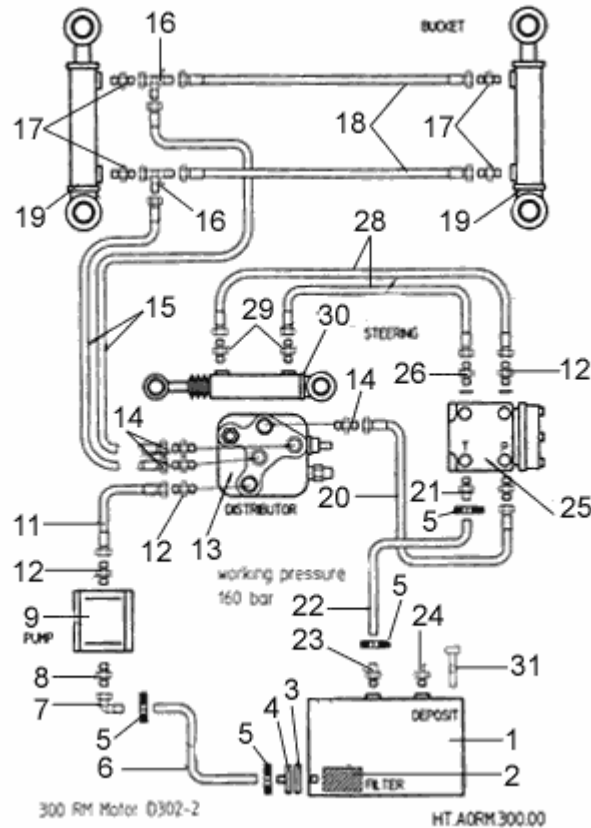

FIGURE	REFERENCE	DENOMINATION	AMOUNT
001	15.01420.03	TANK	1
002	09.00630.61	OIL FILTER ASP. 25 L/MIN	1
003	201.75003.50	O-RING DIN3770 75x81x3	1
004	02.01432.01	COVER HANDHOLE	1
006	15.01239.00	TUBO GOMA B/P 15x25x1500	1
007	08.30620.00	ADMISSION TUBE	1
008	47.01432.00	NIPPLE M/M	1
009	15.01203.03	HYDR. PUMP	1
011	51.01442.00	HOSE R2T1/2	1
012	08.00313.00	FITTING M/M 1/2 G-3/8 G	1
013	09.00330.00	CONTROL VALVE 1E	1
014	08.00319.00	NIPPLE M/M	1
015	54.01823.00	HOSE R1T3/8	1
016	44.01453.00	THREE-WAY UNION M/M/TL	1
017	08.00319.00	NIPPLE M/M	1
018	10.00698.00	HOSE R1T3/8	1
019	08.00500.09	CYLINDER D/E	1
020	45.01011.01	HOSE R1T3/8	1

10. HYDRAULIC INSTALLATION WORKING

FIGURE	REFERENCE	DENOMINATION	AMOUNT
021	52.00108.00	NIPPLE M/M	1
022	15.01615.00	TUBO GOMA B/P 15x25x1124	1
023	08.00301.00	NIPPLE M/TB 1/2G-D16	1
024	45.10803.00	CAP	1
025	31.00613.00	STEERING VALVE	1
026	52.01451.00	NIPPLE M/M 1/2 G-1,1/16 JIC	1
028	46.50110.01	HOSE R1T1/4	1
029	19.00720.00	NIPPLE M/M	1
030	15.01050.02	CYLINDER D/E	1
031	09.00631.00	ROD OIL LEVEL	1

10. HYDRAULIC INSTALLATION

WORKING

CHASSIS: 59188

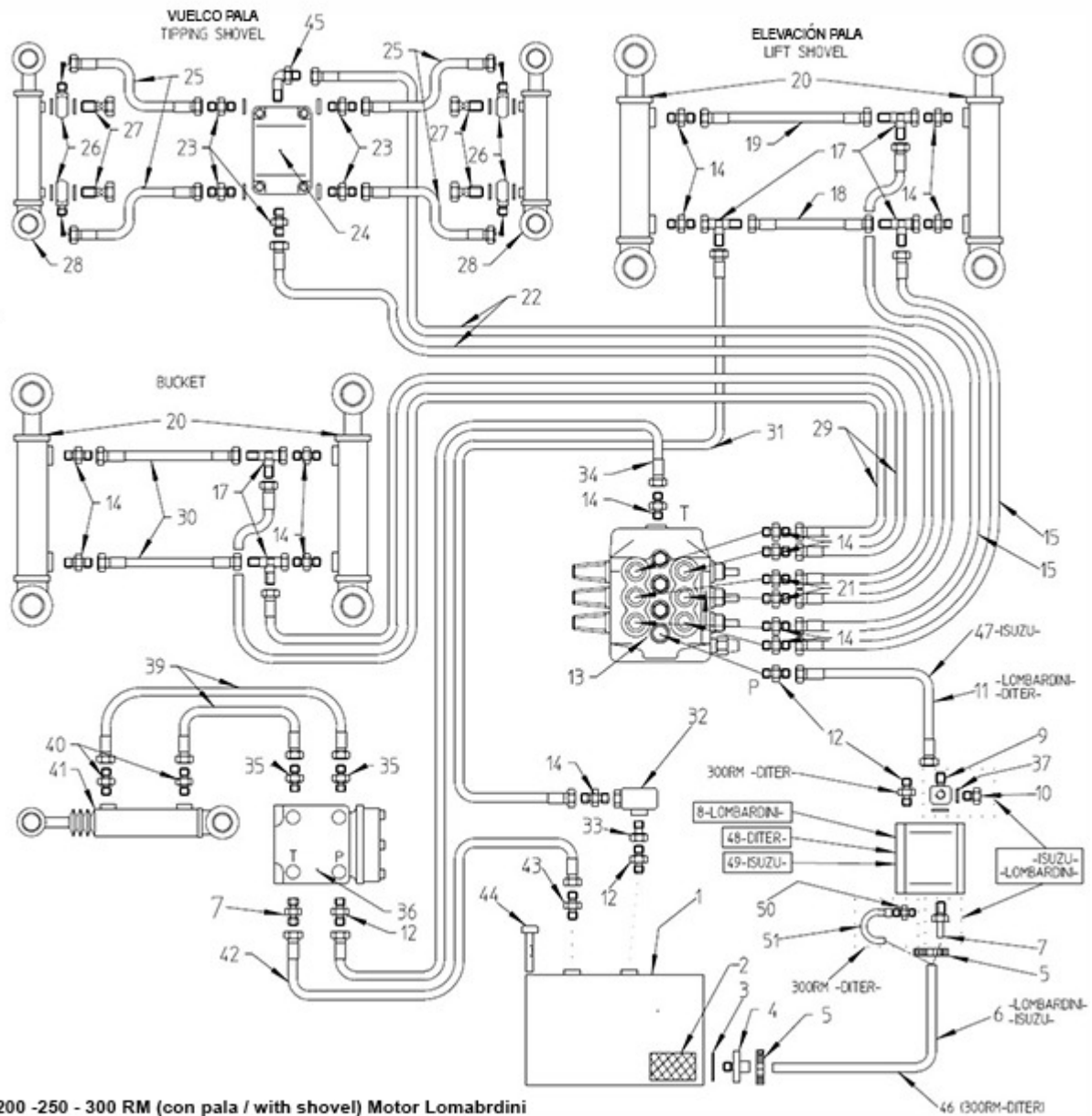

200 -250 - 300 RM (con pala / with shovel) Motor Lomabrdini Diter Isuzu

FIGURE	REFERENCE	DENOMINATION	AMOUNT
001	15.01420.03	TANK	1
002	09.00630.61	OIL FILTER ASP. 25 L/MIN	1
003	201.75003.50	O-RING DIN3770 75x81x3	1
004	02.01432.01	COVER HANDHOLE	1
005	912.20032.00	CLAMP	2
006	15.01615.00	TUBO GOMA B/P 15x25x1124	1
007	08.00301.00	NIPPLE M/TB 1/2G-D16	2
008	15.01205.00	HYDR. PUMP	1
009	08.00311.01	NIPPLE	1

010	08.00320.00	NIPPLE SCREW SIM.	1
011	51.01442.00	HOSE R2T1/2	1
012	08.00313.00	FITTING M/M 1/2 G-3/8 G	4
013	15.00330.00	CONTROL VALVE 3E	1
014	08.00319.00	NIPPLE M/M	14
015	54.01823.00	HOSE R1T3/8	1
016	43.01031.01	HOSE R1T3/8	1
017	44.01453.00	THREE-WAY UNION M/M/TL	5
018	15.01234.00	HOSE R1T3/8	1
019	15.01235.00	HOSE R1T3/8	1
020	08.00500.09	CYLINDER D/E	2
021	19.00720.00	NIPPLE M/M	2
022	15.40125.01	HOSE R1T1/4	2
024	45.01498.00	NIPPLE H/H/H/H	5
025	15.40126.00	HOSE R1T1/4	2
026	28.00339.00	NIPPLE O/M	4
027	28.00340.00	SIMPLE SCREW FITTING 1/4 Gx26	4
028	15.00670.01	CYLINDER D/E	2
029	54.01823.00	HOSE R1T3/8	2
030	10.00698.00	HOSE R1T3/8	2
031	08.00318.00	HOSE R1T3/8	1
032	47.01469.00	VALVE	1
033	60.13016.00	NIPPLE M/TL	1
034	45.01011.01	HOSE R1T3/8	1
035	52.00108.00	NIPPLE M/M	2
036	31.00613.00	STEERING VALVE	1
037	201.19002.50	O-RING DIN3770	1

10. HYDRAULIC INSTALLATION

WORKING

CHASSIS: 59188

FIGURE	REFERENCE	DENOMINATION	AMOUNT
038	08.00301.00	NIPPLE M/TB 1/2G-D16	1
039	46.50110.01	HOSE R1T1/4	2
040	19.00720.00	NIPPLE M/M	2
041	15.01050.02	CYLINDER D/E	1
042	15.01615.00	TUBO GOMA B/P 15x25x1124	1
043	08.00301.00	NIPPLE M/TB 1/2G-D16	1
044	09.00631.00	ROD OIL LEVEL	1
045	15.01453.00	ELBOW C90M/TL NIPPLE	1
046	15.01239.00	TUBO GOMA B/P 15x25x1500	1
047	51.01442.01	HOSE R2T1/2	1

DUMPERS

300 RM /RMA



048	15.01203.03	HYDR. PUMP	1
049	15.01157.00	HYDR. PUMP (ISUZU)	1
050	47.01432.00	NIPPLE M/M	1
051	08.30620.00	ADMISSION TUBE	1

COMMENTS

MOD.3722

10. HYDRAULIC INSTALLATION

OIL TANK

CHASSIS: 32274

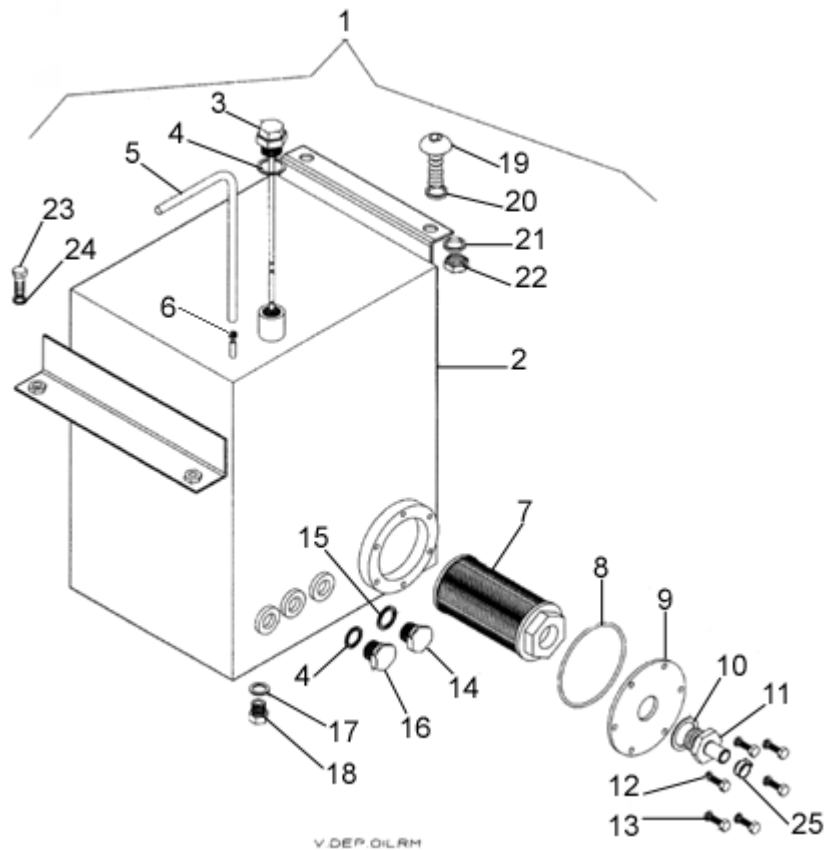

FIGURE	REFERENCE	DENOMINATION	AMOUNT
001	15.14200.01	DEPOSITO ACEITE COMP.	1
002	15.01420.03	TANK	1
003	09.00631.00	ROD OIL LEVEL	1
004	08.00316.01	GASKET MET. BUNA	2
005	15.10750.00	TUBO PLAS. TRANS. D6xD9x300	1
006	948.00907.00	CLAMP SPRING D9	1
007	09.00630.61	OIL FILTER ASP. 25 L/MIN	1
008	201.75003.50	O-RING DIN3770 75x81x3	1
009	02.01432.02	AD. FILTER SUPPORT	1
010	45.01423.00	GASKET	1
011	08.00301.00	NIPPLE M/TB 1/2G-D16	1
012	104.06000.00	WASHER DIN7980 D6	6
013	603.06015.86	SCREW DIN933 M6x15	6
014	45.10803.10	CAP M22x1,5	1
015	106.22000.20	WASHER CU	1
016	45.10803.00	CAP	1
017	107.14000.10	WASHER AL 14x20x1.5	1
018	00.02803.00	SCREW DIN910*	1

10. HYDRAULIC INSTALLATION

OIL TANK

CHASSIS: 32274

FIGURE	REFERENCE	DENOMINATION	AMOUNT
019	630.10025.96	SCREW ISO7380	2
020	104.10000.00	WASHER DIN7980 D10	2
021	101.10000.66	WASHER DIN125 D10	2
022	701.10000.66	NUT DIN934 M10x1.5	2
023	603.08025.80	SCREW DIN933	2
024	104.08000.00	WASHER DIN7980 D8	2
025	912.20032.00	CLAMP	1

10. HYDRAULIC INSTALLATION DISTRIBUTOR

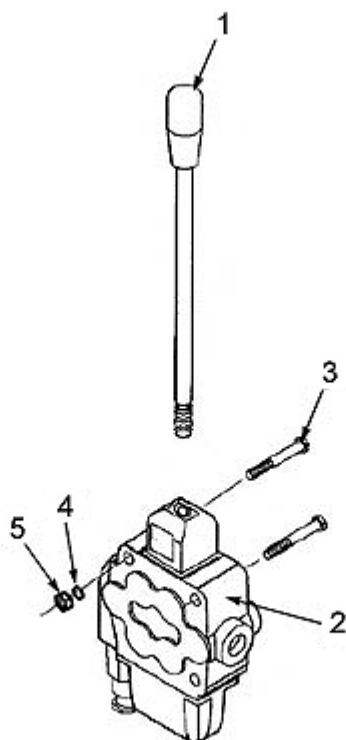

FIGURE	REFERENCE	DENOMINATION	AMOUNT
001	09.01451.00	CONTROL LEVER	1
002	09.00330.00	CONTROL VALVE 1E	1
003	601.08065.86	SCREW DIN912 M8x65	2
004	101.08000.66	WASHER DIN125 D8	2
005	711.08000.66	NUT DIN982 M8	2

ELECTRIC INSTALLATION STARTING

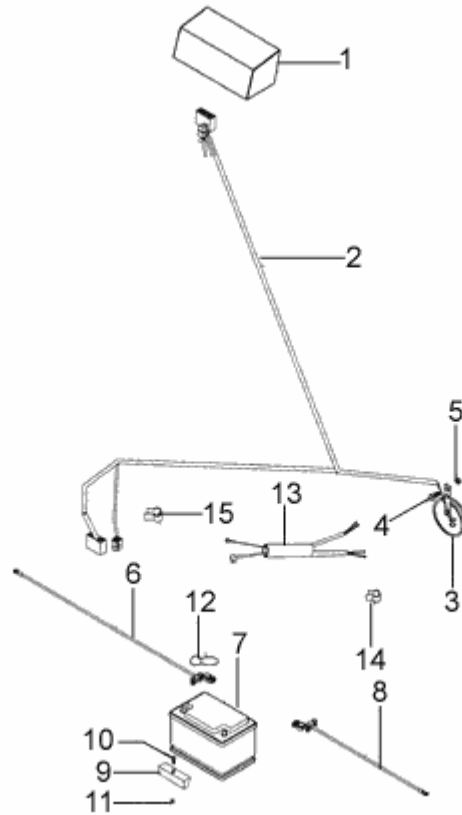

FIGURE	REFERENCE	DENOMINATION	AMOUNT
001	60.45070.01	TABLIER 106.5x115x300 COMP	1
002	15.01450.02	ELECTRICAL CABLE	1
003	00.09034.00	HORN	1
004	603.08015.86	SCREW DIN933 M8x15	1
005	701.08000.66	NUT DIN934 M8X1,25	1
006	15.01443.00	ELECTRICAL CABLE	1
007	15.01411.00	BATTERY 12VX70AH	1
008	01.00842.00	ELECTRICAL CABLE	1
009	43.10827.01	FIXING SUPPORT	1
010	603.06035.86	SCREW DIN933 M6x35	1
011	726.06002.66	NUT	1
012	46.10002.00	TERMINAL PROTECTOR	1
014	830.02206.00	CLAMP LOOP	1
015	830.02210.00	CLAMP LOOP	1

ELECTRIC INSTALLATION

STARTING

CHASSIS: 59188

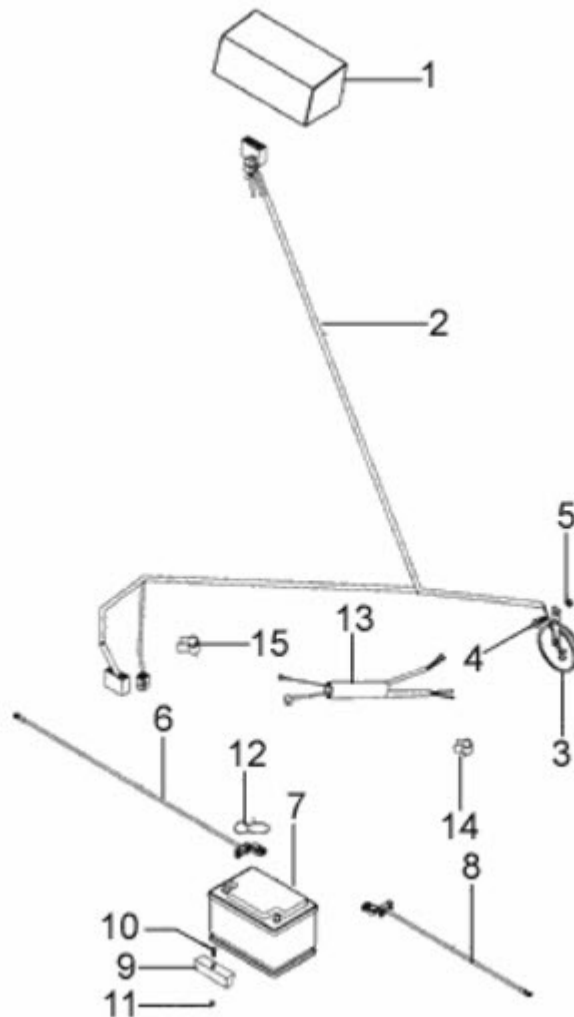

FIGURE	REFERENCE	DENOMINATION	AMOUNT
001	60.45070.01	TABLIER 106.5x115x300 COMP	1
002	34.01450.07	ELECTRICAL CABLE	1
003	00.09034.00	HORN	1
004	603.08015.86	SCREW DIN933 M8x15	1
005	701.08000.66	NUT DIN934 M8X1,25	1
006	15.01443.00	ELECTRICAL CABLE	1
007	15.01411.00	BATTERY 12VX70AH	1
008	01.00842.00	ELECTRICAL CABLE	1
009	43.10827.01	FIXING SUPPORT	1
010	603.06035.86	SCREW DIN933 M6x35	1
011	726.06002.66	NUT	1
012	46.10002.00	TERMINAL PROTECTOR	1
014	830.02206.00	CLAMP LOOP	1
015	830.02210.00	CLAMP LOOP	1

COMMENTS

MOD.3722

ELECTRIC INSTALLATION

STARTING BOARD

CHASSIS: 45951

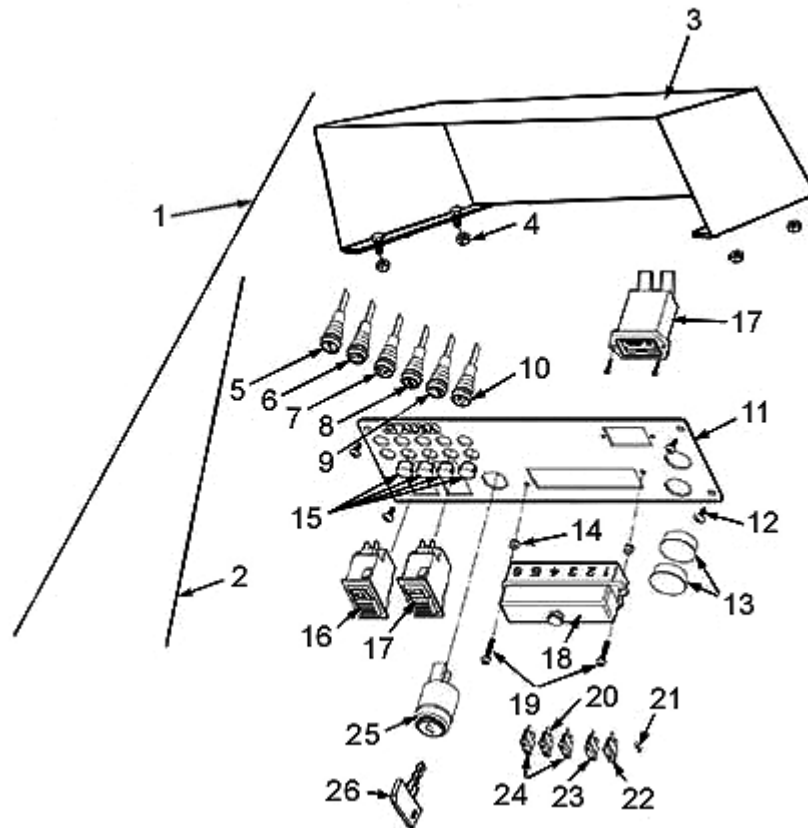

FIGURE	REFERENCE	DENOMINATION	AMOUNT
001	60.45070.01	TABLIER 106.5x115x300 COMP	1
002	60.04507.09	DASH, PANEL	1
003	09.00922.04	SUPPORT PLATE	1
004	701.06000.66	NUT DIN934 M6X1	4
005	IM.20108.00	WATER TEMPERATURE INDICATOR	1
006	IM.20110.00	GENERATOR INDICATOR	1
007	IM.20109.00	OIL PRESSURE INDICATOR	1
008	IM.20113.00	AIR FILTER INDICATOR	1
009	IM.20116.00	LUZ TESTIGO NIVEL COMB.	1
010	IM.20114.00	PRE HEATING INDICATOR	1
011	09.00924.10	TAPA. 2X104X296 MANDOS ELEC.	1
012	630.06015.96	SCREW ISO7380 M6x15	1
025	01.00823.03	CONMUTATOR	1
026	01.08223.03	KEY	1

ELECTRIC INSTALLATION

STARTING BOARD

CHASSIS: 59188



FIGURE	REFERENCE	DENOMINATION	AMOUNT
000	15.09230.02	INSTRUMENT PANEL	1
001	09.00924.10	TAPA. 2X104X296 MANDOS ELEC.	1
002	IM.20100.00	CONTADOR HORAS	1
003	12.11052.00	ROTARY LIGHT SWITCH	1
004	12.11051.00	HORN SWITCH	1
005	IM.20101.00	CONMUTATOR WITH KEY	1
006	IM.20101.01	KEY OF THE START SWITCH IM.20101.00	1
007	IM.20108.00	WATER TEMPERATURE INDICATOR	1
008	IM.20116.00	LUZ TESTIGO NIVEL COMB.	1
009	IM.20110.00	GENERATOR INDICATOR	1
010	IM.20114.00	PRE HEATING INDICATOR	1
011	IM.20109.00	OIL PRESSURE INDICATOR	1

012	IM.20115.00	TAPA. D22MM	2
013	IM.20113.00	AIR FILTER INDICATOR	1
014	IM.20104.00	CAJA. PORTAFUSIBLES 6 U.	1
015	43.50043.00	FUSE 20A	2
016	43.50032.00	FUSE 15A	1
017	IM.20028.00	FUSE	1
018	43.50045.00	RESISTENCIA 150 OHM 2W	1
019	43.50035.00	DIODE	1
020	15.01451.03	ELECTRICAL PANEL	1

COMMENTS

MOD.3722

ELECTRIC INSTALLATION LIGHTING

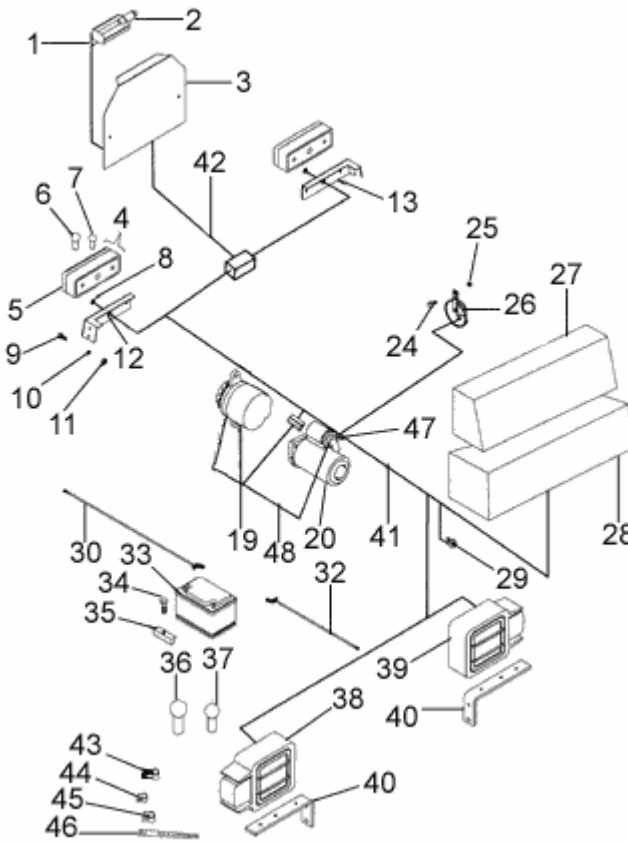

FIGURE	REFERENCE	DENOMINATION	AMOUNT
001	46.10755.00	NUMBER PLATE LIGHT	1
002	46.01324.00	LAMP 12V 5W	1
003	46.10754.00	PIN SUPPORT 25x195x250	1
004	54.01327.00	PILOT	2
005	31.13270.00	DIFUSOR PILOTO	2
006	31.01329.00	LAMP 12V 21W	1
007	31.01331.00	LAMP 12V 21W/5W	1
008	16.01155.00	GROMMET D11XD15XD19X4X8	2
009	603.06020.86	SCREW DIN933 M6x20	2
010	104.06000.00	WASHER DIN7980 D6	2
011	701.06000.66	NUT DIN934 M6X1	2
012	15.01449.00	LIGHT SUPPORT	1
013	15.01448.00	LIGHT SUPPORT	1
019	83.89058.01	GENERATOR	1
020	87.00154.01	STARTER ENGINE	1
024	603.06020.86	SCREW DIN933 M6x20	1
025	701.06000.66	NUT DIN934 M6X1	1
026	00.09034.00	HORN	1

ELECTRIC INSTALLATION LIGHTING

FIGURE	REFERENCE	DENOMINATION	AMOUNT
027	60.45070.02	TABLIER	1
028	60.00933.00	SUPPORT PLATE	1
029	43.01520.00	BRAKE FLUID SWITCH	1
030	15.01443.00	ELECTRICAL CABLE	1
032	01.00842.00	ELECTRICAL CABLE	1
032	15.01444.00	ELECTRICAL CABLE	1
033	15.01411.00	BATTERY 12VX70AH	1
034	603.06030.86	SCREW DIN933 M6x30	1
035	43.10827.00	FIXING SUPPORT	1
036	31.01329.00	LAMP 12V 21W	2
037	31.01331.00	LAMP 12V 21W/5W	2
038	00.09032.10	BEACON	1
039	00.09032.11	BEACON	1
040	15.01447.00	LIGHT SUPPORT	2
041	15.70237.00	LENGTH ELEC. INSTAL.	1
042	01.00885.00	LENGTH ELEC. INSTAL.	1
043	830.01806.00	CLAMP LOOP	1
044	946.01200.00	CLAMP SPRING	1
045	946.01400.00	CLAMP SPRING	1
046	931.05370.00	CLAMP TAPE 5x370	1
047	01.00899.00	PROTECTOR	1
048	55.13125.00	LENGTH ELEC. INSTAL.	1

ELECTRIC INSTALLATION

LIGHTING PANEL

CHASSIS: 50432

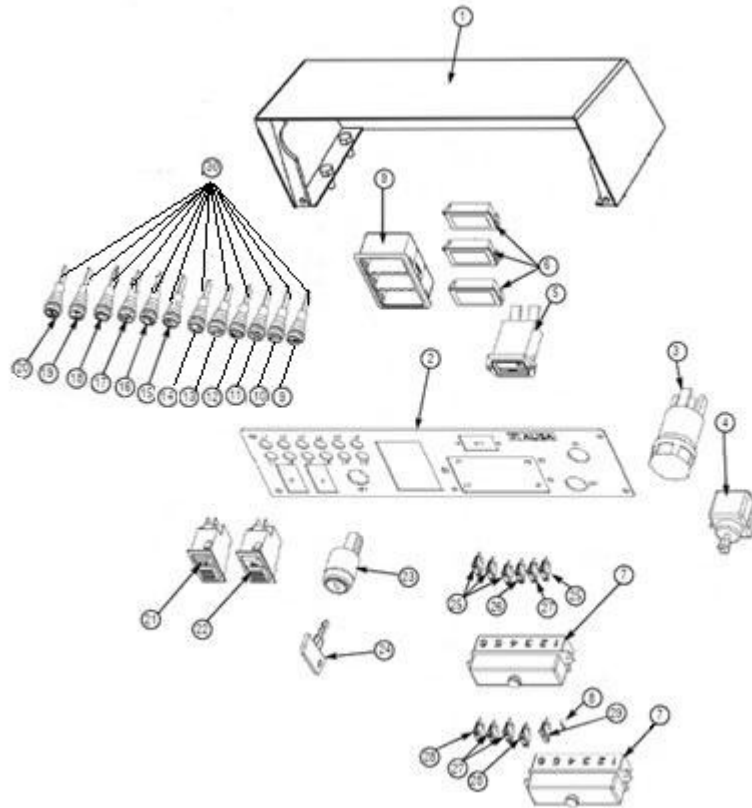

FIGURE	REFERENCE	DENOMINATION	AMOUNT
001	09.00924.20	TAPA. 2X104X396 MANDOS ELEC.	1
002	43.50045.00	RESISTENCIA 150 OHM 2W	1
003	43.50023.00	0	1
004	43.50026.00	CONMUTATOR	1
005	IM.20100.00	CONTADOR HORAS	1
006	IM.20103.00	TAPA. INTERRUPTOR	3
007	IM.20104.00	CAJA. PORTAFUSIBLES 6 U.	2
008	43.50045.00	RESISTENCIA 150 OHM 2W	1
009	IM.20102.00	CAJA. 3VIAS SWF	1
010	IM.20117.00	LUZ TESTIGO MARCHA LENTA	1
011	IM.20118.00	LUZ TESTIGO MARCHA RAPIDA	1
012	IM.20112.00	BEAM LIGHTS INDICATOR	1
013	IM.20111.00	LUZ TESTIGO LUZ POSIC.	1
014	IM.20107.00	INTERMITTENT LIGHT INDICATOR	1
015	IM.20114.00	PRE HEATING INDICATOR	1
016	IM.20116.00	LUZ TESTIGO NIVEL COMB.	1
017	IM.20109.00	OIL PRESSURE INDICATOR	1
018	IM.20110.00	GENERATOR INDICATOR	1

ELECTRIC INSTALLATION**LIGHTING PANEL**

CHASSIS: 50432

FIGURE	REFERENCE	DENOMINATION	AMOUNT
019	IM.20108.00	WATER TEMPERATURE INDICATOR	1
020	IM.20113.00	AIR FILTER INDICATOR	1
021	12.11052.00	ROTARY LIGHT SWITCH	1
022	12.11050.00	TULIPA INTERRUPTOR WARNING	1
023	01.00823.03	CONMUTATOR	1
024	01.08223.03	KEY	1
025	43.50032.00	FUSE 15A	4
026	43.50042.00	FUSE 25A	1
027	43.50029.00	FUSIBLE 7.5A	3
028	43.50043.00	FUSE 20A	2
029	43.50044.00	DIODO 3A	1
030	IM.20105.00	LAMP 12V	1

12. FINISHES

PLATES

CHASSIS: 44745

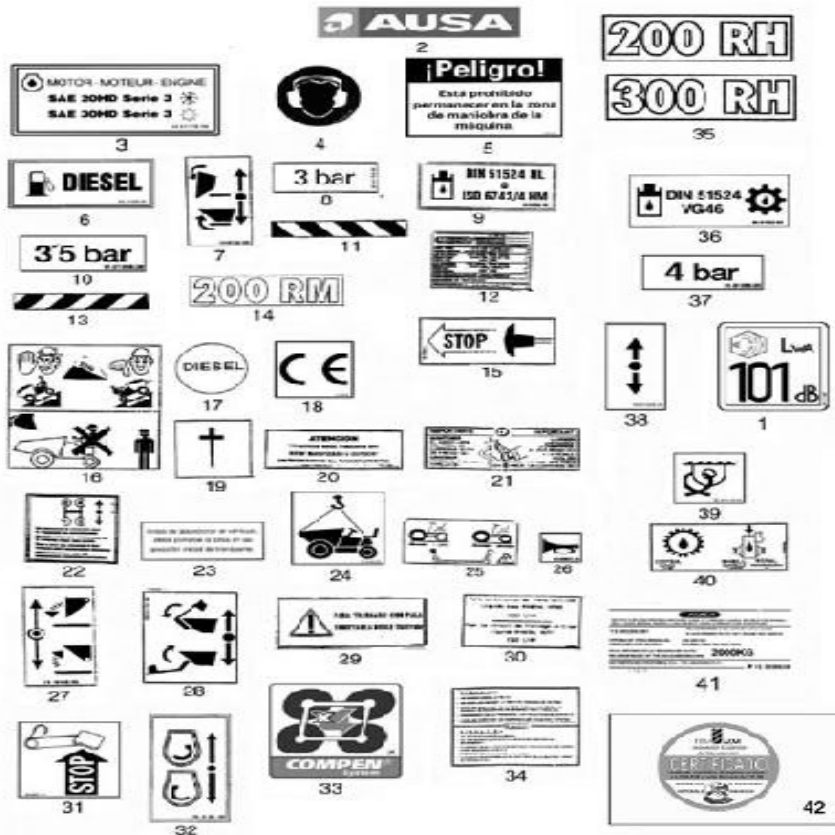

FIGURE	REFERENCE	DENOMINATION	AMOUNT
001	09.12011.00	ADHESIVE	1
002	13.12136.00	ADHESIVE 450x92	4
003	43.01170.02	PLATE AD. INDI	1
003.2	43.01170.03	INDICATIVE STICKER 90x45 ENGINE OIL TYPE	1
004	01.00757.00	PLATE AD. INDI	1
005	14.00775.01	PLATE AD. INDI	1
005	14.00775.02	PLATE AD. INDI	1
006	43.01356.00	PLATE AD. INDI	1
007	09.01351.00	PLATE AD. INDI	1
008	01.01355.03	PLATE AD. INDI	1
009	43.01352.10	PLATE AD. INDI	1
009	60.01352.00	PLATE AD. INDI	1
010	01.01355.08	PLATE AD. INDI	2
011	39.09901.00	PLATE AD. INDI	1
012	01.00779.26	PLATE - CONTACT WITH AUSA	1
013	39.09901.00	PLATE AD. INDI	1
014	15.20004.01	INDICATOR	2
015	15.20010.00	PLATE AD. INDI	1

12. FINISHES

PLATES

CHASSIS: 44745

FIGURE	REFERENCE	DENOMINATION	AMOUNT
016	09.00769.00	PLATE AD. INDI	1
017	15.01525.00	PLATE AD. INDI	1
018	45.19101.00	PLATE AD. INDI	2
019	502.03000.60	RIVET DIN1476	4
020	02.00774.00	PLATE AD. INDI	1
021	45.00760.00	PLATE AD. INDI	1
022	01.01354.01	PLATE AD. INDI	1
023	02.00773.01	PLATE AD. INDI	1
023	02.00773.02	PLATE AD. INDI	1
024	01.01353.00	PLATE AD. INDI	1
025	15.01181.03	PLATE INDI.	1
026	46.00825.00	PLATE AD. INDI	1
027	09.10156.00	PLATE AD. INDI	1
028	09.10155.00	PLATE AD. INDI	1
029	15.30250.00	PLATE AD. INDI	1
029	15.30250.01	PLATE AD. INDI	1
029	15.30250.02	PLATE AD. INDI	1
029	15.30250.03	PLATE AD. INDI	1
030	55.00780.00	PLATE AD. INDI	1
031	08.00921.00	PLATE AD. INDI	1
032	08.01351.00	PLATE AD. INDI	1
033	43.00395.01	PLATE AD. INDI	2
034	14.00770.00	PLATE AD. INDI	1
037	01.01355.05	PLATE AD. INDI	1
038	58.01354.00	PLATE AD. INDI	1
039	09.15720.00	PLATE AD. INDI	1
040	43.00396.00	PLATE AD. INDI	1
041	15.08260.00	PLATE AD. INDI	1
042	00.00013.00	ADHESIVE	1

12. FINISHES

PLATES

CHASSIS: 70415

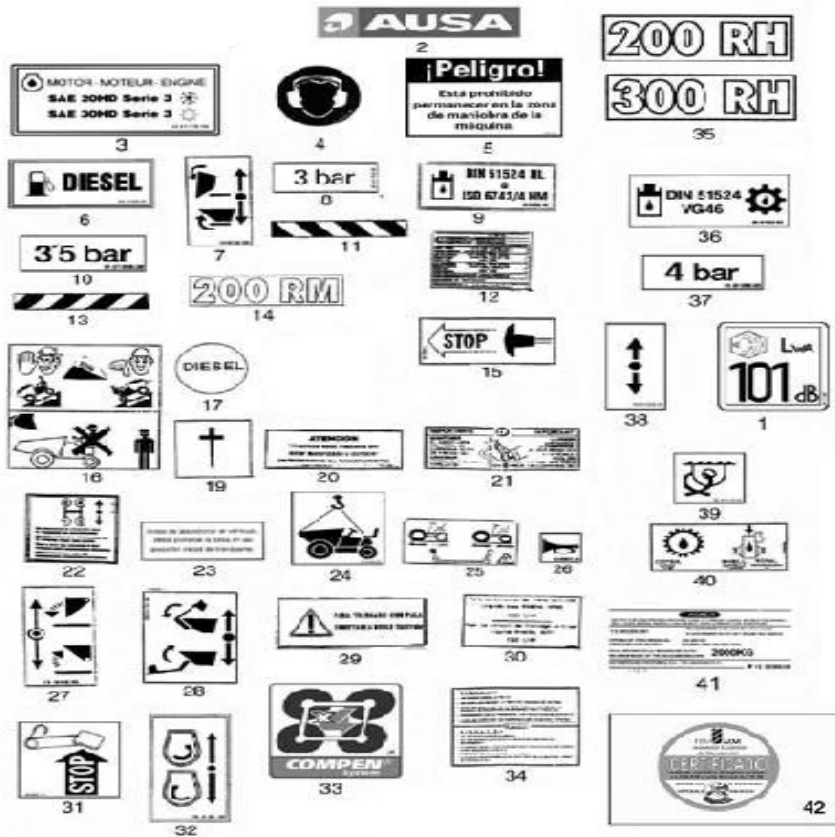

FIGURE	REFERENCE	DENOMINATION	AMOUNT
001	09.12011.00	ADHESIVE	1
002	13.12136.00	ADHESIVE 450x92	4
003	43.01170.02	PLATE AD. INDI	1
003.2	43.01170.03	INDICATIVE STICKER 90x45 ENGINE OIL TYPE	1
004	01.00757.00	PLATE AD. INDI	1
005	14.00775.01	PLATE AD. INDI	1
005	14.00775.02	PLATE AD. INDI	1
006	43.01356.00	PLATE AD. INDI	1
007	09.01351.00	PLATE AD. INDI	1
008	01.01355.03	PLATE AD. INDI	1
009	43.01352.10	PLATE AD. INDI	1
009	60.01352.00	PLATE AD. INDI	1
010	01.01355.08	PLATE AD. INDI	2
011	39.09901.00	PLATE AD. INDI	1
012	01.00779.26	PLATE - CONTACT WITH AUSA	1
013	39.09901.00	PLATE AD. INDI	1
014	15.20004.01	INDICATOR	2
015	15.20010.00	PLATE AD. INDI	1

12. FINISHES

PLATES

CHASSIS: 70415

FIGURE	REFERENCE	DENOMINATION	AMOUNT
016	09.00769.00	PLATE AD. INDI	1
017	15.01525.00	PLATE AD. INDI	1
019	502.03000.60	RIVET DIN1476	4
020	02.00774.00	PLATE AD. INDI	1
021	45.00760.00	PLATE AD. INDI	1
022	01.01354.01	PLATE AD. INDI	1
023	02.00773.01	PLATE AD. INDI	1
023	02.00773.02	PLATE AD. INDI	1
024	01.01353.00	PLATE AD. INDI	1
025	15.01181.03	PLATE INDI.	1
026	46.00825.00	PLATE AD. INDI	1
027	09.10156.00	PLATE AD. INDI	1
028	09.10155.00	PLATE AD. INDI	1
029	15.30250.00	PLATE AD. INDI	1
029	15.30250.01	PLATE AD. INDI	1
029	15.30250.02	PLATE AD. INDI	1
029	15.30250.03	PLATE AD. INDI	1
030	55.00780.00	PLATE AD. INDI	1
031	08.00921.00	PLATE AD. INDI	1
032	08.01351.00	PLATE AD. INDI	1
033	43.00395.01	PLATE AD. INDI	2
034	14.00770.00	PLATE AD. INDI	1
037	01.01355.05	PLATE AD. INDI	1
038	58.01354.00	PLATE AD. INDI	1
039	09.15720.00	PLATE AD. INDI	1
040	43.00396.00	PLATE AD. INDI	1
041	15.08260.00	PLATE AD. INDI	1
042	00.00013.00	ADHESIVE	1

OPTION AND VARIANTS
DRIVER PROTECTOR ROOF
CHASSIS: 39616

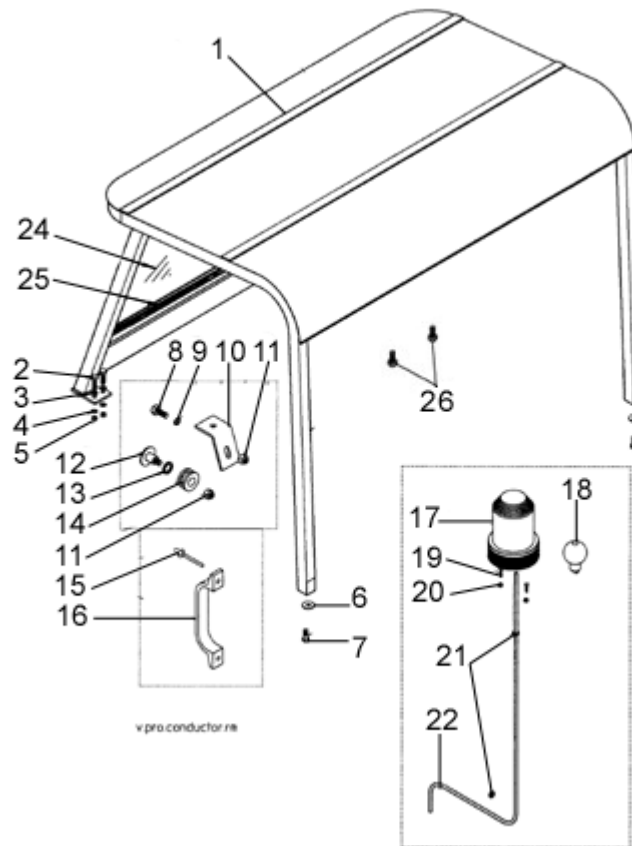

FIGURE	REFERENCE	DENOMINATION	AMOUNT
001	15.08250.01	DRIVER GUARD	1
002	604.12040.86	SCREW DIN931	4
003	101.12000.66	WASHER DIN125 D12	4
004	104.12000.00	WASHER DIN7980 D12	4
005	701.12000.66	NUT DIN934 M12x1.75	4
006	112.10000.66	WASHER DIN9021 D10	2
007	604.12030.86	SCREW DIN931	2
008	630.06020.96	SCREW ISO7380 M6x20	2
009	112.06000.66	WASHER DIN9021 D6	2
010	01.08251.00	BRACKET ANG.	1
011	711.06000.66	NUT DIN982 M6	10
012	43.50941.00	SCREW DIN923*	9
013	101.06000.66	WASHER DIN125 D6	9
014	16.00760.00	BUSH	9
015	615.04015.66	SCREW DIN84 M4x15	4
016	46.09991.00	KNOB	2
017	01.00921.00	BEACON	1
018	01.00923.00	BULB	1

OPTION AND VARIANTS

DRIVER PROTECTOR ROOF

CHASSIS: 39616

FIGURE	REFERENCE	DENOMINATION	AMOUNT
019	603.06015.86	SCREW DIN933 M6x15	3
020	711.06000.66	NUT DIN982 M6	3
021	43.07777.00	GROMMET	2
022	01.00927.01	LENGTH ELEC. INSTAL.	1
023	711.04000.66	NUT	4
024	15.08252.00	GLASS	1
025	15.08253.00	PERFIL 8x15x1505 GOMA	1
026	619.05016.86	SCREW DIN7971 4.8X16	2

OPTION AND VARIANTS
WINDSCREEN WIPERS
CHASSIS: 32859

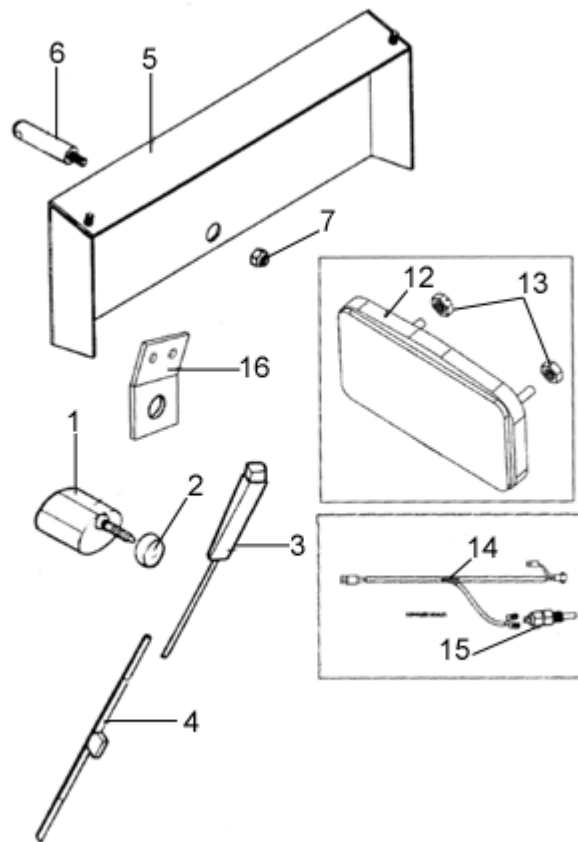

FIGURE	REFERENCE	DENOMINATION	AMOUNT
001	46.00843.00	MOTOR WINDSCREEN WIPER	1
002	01.00804.01	BUSH	1
003	46.00841.00	WINDSCREEN WIPER ARM	1
004	46.00842.00	WINDSCREEN WIPER BLADE	1
005	60.01454.00	BULB GUARD	1
006	60.01453.00	AXLE CIL/ROS	1
007	711.06000.66	NUT DIN982 M6	1
012	14.40901.00	RED REFLECTOR	1
013	701.05000.66	NUT DIN934 M5x0.8	2
014	02.14109.00	LENGTH ELEC. INSTAL.	1
015	45.01525.00	SWITCH	1
016	15.08251.00	STRIGHT SUPPORT	1

OPTION AND VARIANTS

REAR-VISION MIRROR

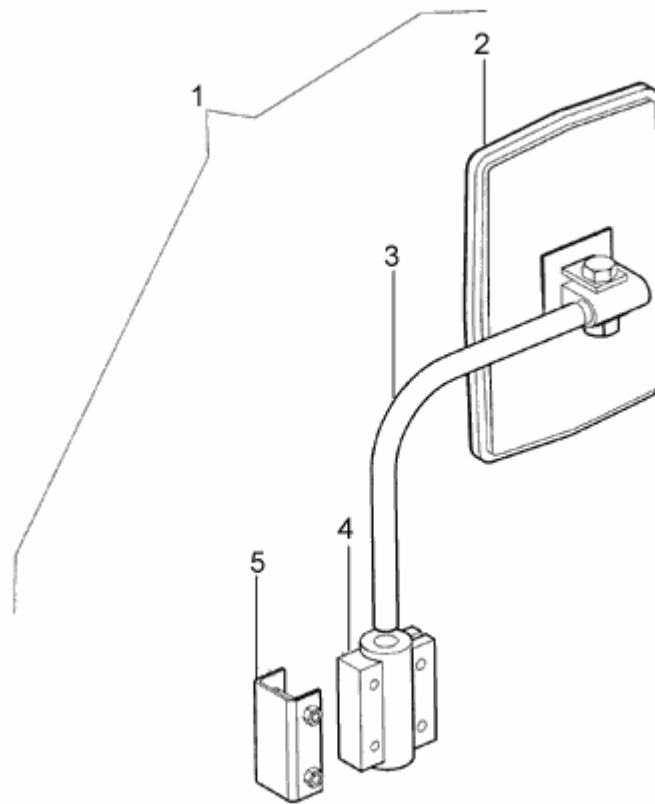
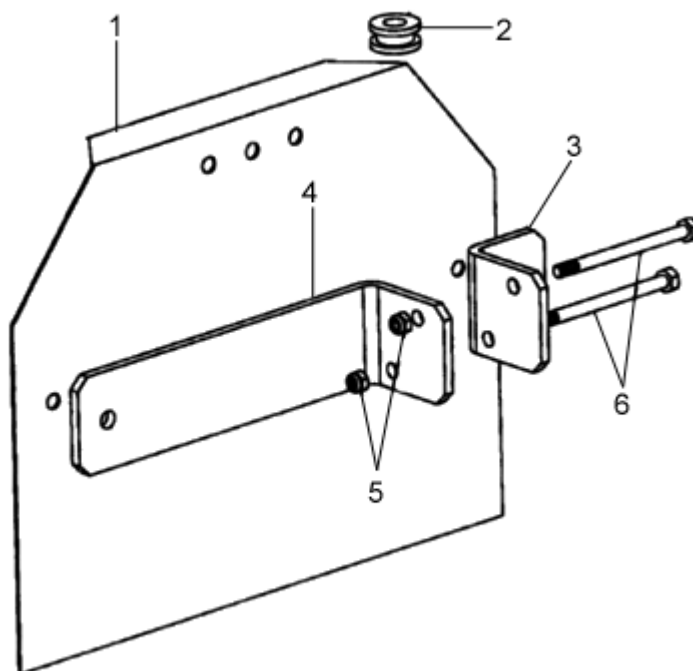

FIGURE	REFERENCE	DENOMINATION	AMOUNT
001	09.11009.00	REARVIEW MIRROR COMPLETE ASSY	1
002	09.11009.00	REARVIEW MIRROR COMPLETE ASSY	1
003	09.11010.00	SUPPORT 16X143X143	1
004	09.11011.00	AXLE SUPPORT MIRROR	1
005	09.11012.00	SOP. EJE 18X25X75 RETROVISOR	1

OPTION AND VARIANTS LIGHTS APPLICATION



v.opcion.luces aplicacion.retro

FIGURE	REFERENCE	DENOMINATION	AMOUNT
001	46.10754.00	PIN SUPPORT 25x195x250	1
002	21.00161.00	GROMMET	1
003	15.10628.00	BRACKET ANG.	1
004	15.10627.00	BRACKET ANG.	1
005	711.05000.66	NUT DIN982 M5	2
006	604.05065.86	SCREW DIN931	2

SHOVEL APPLICATION BUCKET ARM

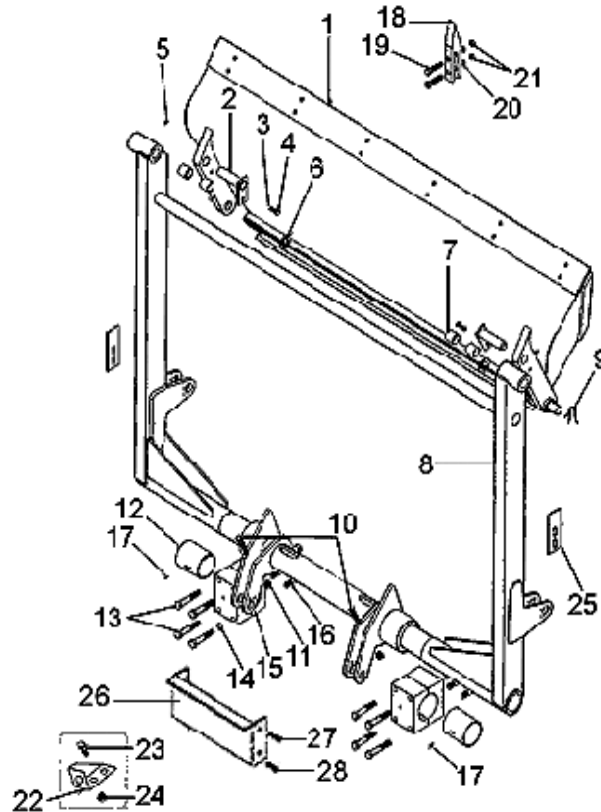

FIGURE	REFERENCE	DENOMINATION	AMOUNT
001	15.30230.01	SKIP RM-RH	1
002	09.10102.01	AXLE CIL/CPA	2
003	104.10000.00	WASHER DIN7980 D10	2
004	603.10020.86	SCREW DIN933 M10x20	2
005	901.08000.33	GREASER DIN71412-A M8x1,25	4
006	101.30000.66	WASHER DIN125 D30	4
007	08.00527.00	BEARING	4
008	15.30200.04	SHOVEL ARM	1
009	401.04050.60	PIN DIN94 4x50	2
010	603.14080.86	SCREW DIN933	2
011	701.14000.66	NUT DIN934 M14x2	2
012	15.00926.00	BEARING	2
013	604.16100.86	SCREW DIN931	8
014	104.16000.00	CIR-CLIP EXT. DIN7980	16
015	15.00925.00	BEARING SUPPORT	16
016	604.16050.86	SCREW DIN931 M16x50	4
017	402.04020.00	PIN	2
018	15.30302.00	BUCKET TOOTH	6

SHOVEL APPLICATION BUCKET ARM

FIGURE	REFERENCE	DENOMINATION	AMOUNT
019	604.12045.96	SCREW DIN931 M12x45	12
020	104.12000.00	WASHER DIN7980 D12	12
021	701.12000.66	NUT DIN934 M12x1.75	12
022	55.00835.00	BUTT	2
023	603.14045.86	SCREW DIN933 M14x45	4
024	711.14000.66	NUT DIN982 M14 8.8 K	4
025	15.12110.00	PROTECTOR 5x50x130 GOMA	2
026	15.30119.00	STRIP SUPPORT	1
027	104.08000.00	WASHER DIN7980 D8	4
028	603.08020.86	SCREW DIN933 M8x20	4

SHOVEL APPLICATION

ARM CYLINDER SUPPORT

CHASSIS: 43608

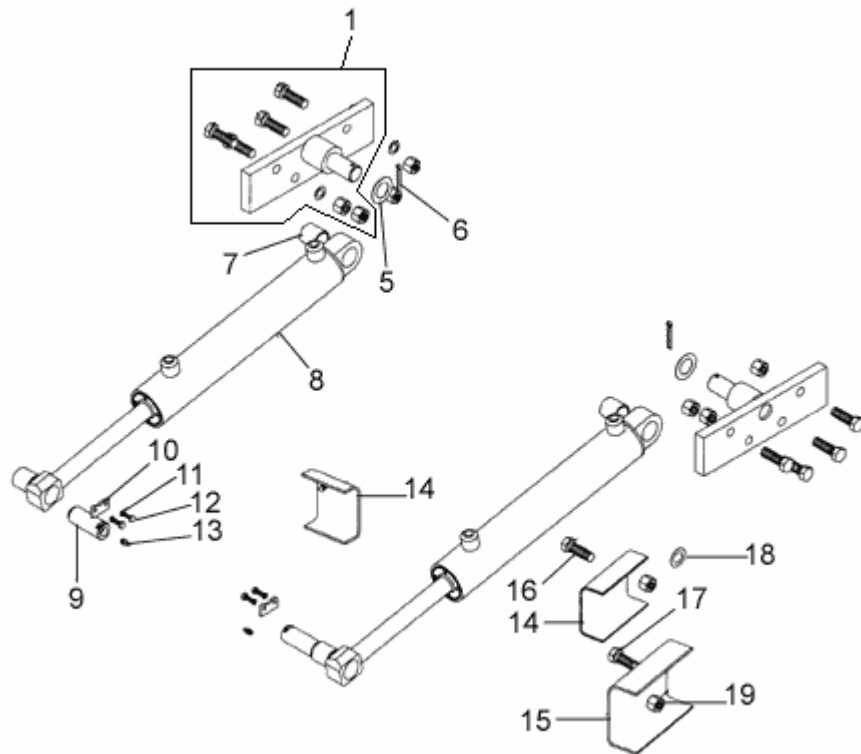

FIGURE	REFERENCE	DENOMINATION	AMOUNT
001	15.30220RE00	Cylinder Articulated Full Support	1
005	101.30000.66	WASHER DIN125 D30	2
006	401.05060.60	PIN	2
007	08.00527.00	BEARING	4
008	08.00500.09	CYLINDER D/E	2
009	15.01216.00	SHAFT CIL/COA	2
010	15.00832.00	PANEL	2
011	104.06000.00	WASHER DIN7980 D6	4
012	603.06015.86	SCREW DIN933 M6x15	4
013	901.08000.33	GREASER DIN71412-A M8x1,25	2
014	15.10993.00	CLAMP U	3
015	15.10994.00	CLAMP U	1
016	604.06030.86	SCREW DIN931	3
017	604.06045.86	SCREW DIN931 M6x45	1
018	104.06000.00	WASHER DIN7980 D6	4
019	711.06000.66	NUT DIN982 M6	4

SHOVEL APPLICATION BUCKET CYLINDER

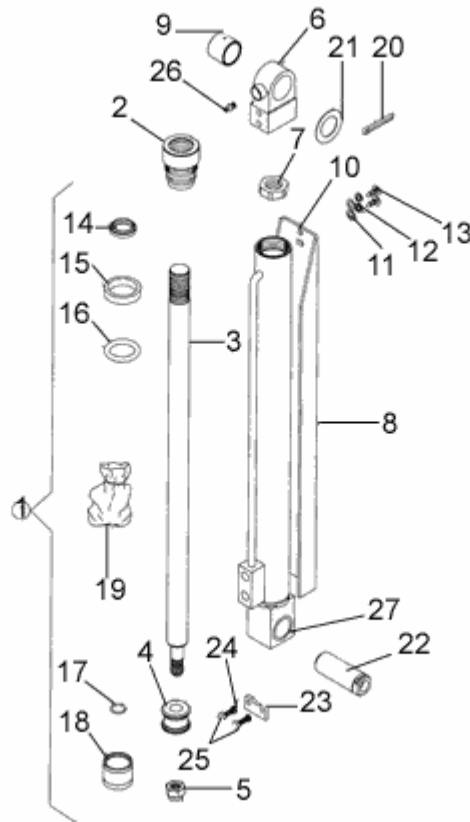

FIGURE	REFERENCE	DENOMINATION	AMOUNT
001	15.00670.01	CYLINDER D/E	2
002	15.00676.00	GUIDE	1
003	15.00677.00	SPINDLE	1
004	10.00675.02	PISTON	1
005	718.16015.66	NUT	1
006	60.01115.04	CYLINDER ROD HEAD	1
007	54.01117.00	NUT	1
008	15.00671.01	CYL. BARREL	1
009	55.00527.00	BUSH	2
010	15.10670.01	CYL. GUARD	1
011	101.08000.66	WASHER DIN125 D8	2
012	104.08000.00	WASHER DIN7980 D8	2
013	630.08015.96	SCREW ISO7380	2
014	228.02836.50	WIPER RING	1
015	229.02838.50	GASKET DIN6505	1
016	201.03335.50	O-RING DIN3770	1
017	201.01725.50	O-RING DIN3770	1
018	207.04032.50	JUNTA ESTAN. COMPAC. 40X32	1

SHOVEL APPLICATION BUCKET CYLINDER

FIGURE	REFERENCE	DENOMINATION	AMOUNT
019	15.99670.00	GASKET SET	1
020	401.04050.60	PIN DIN94 4x50	1
021	101.30000.66	WASHER DIN125 D30	1
022	08.00135.00	SHAFT CIL/COA	1
023	15.00832.00	PANEL	2
024	104.06000.00	WASHER DIN7980 D6	4
025	603.06015.86	SCREW DIN933 M6x15	4
026	901.08000.33	GREASER DIN71412-A M8x1,25	2
027	10.00629.00	BEARING	2

SHOVEL APPLICATION

ARM CYLINDER

CHASSIS: 43608

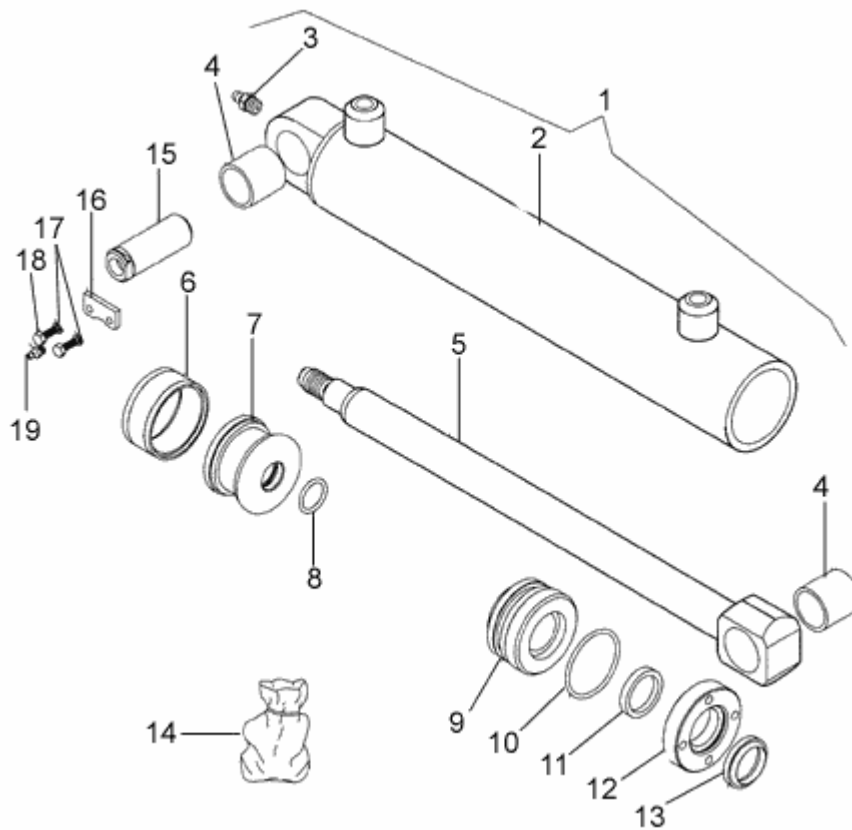

FIGURE	REFERENCE	DENOMINATION	AMOUNT
001	08.00500.09	CYLINDER D/E	2
002	08.00520.04	CUERPO CIL. 63x476 SOLD	2
003	901.08000.33	GREASER DIN71412-A M8x1,25	2
004	08.00527.00	BEARING	4
005	08.00525.01	SPINDLE	2
006	207.63028.50	GASKET	2
007	08.00521.04	PISTON	2
008	201.22003.50	O-RING DIN3770	2
009	08.00528.02	GUIDE	2
010	201.05153.50	O-RING DIN3770	2
011	217.30006.50	GASKET DIN6505	2
012	08.00530.01	NUT	2
013	203.03041.50	WIPER RING	2
014	08.99500RE05	GASKET SET	2

SHOVEL APPLICATION HYDRAULIC INSTALLATION

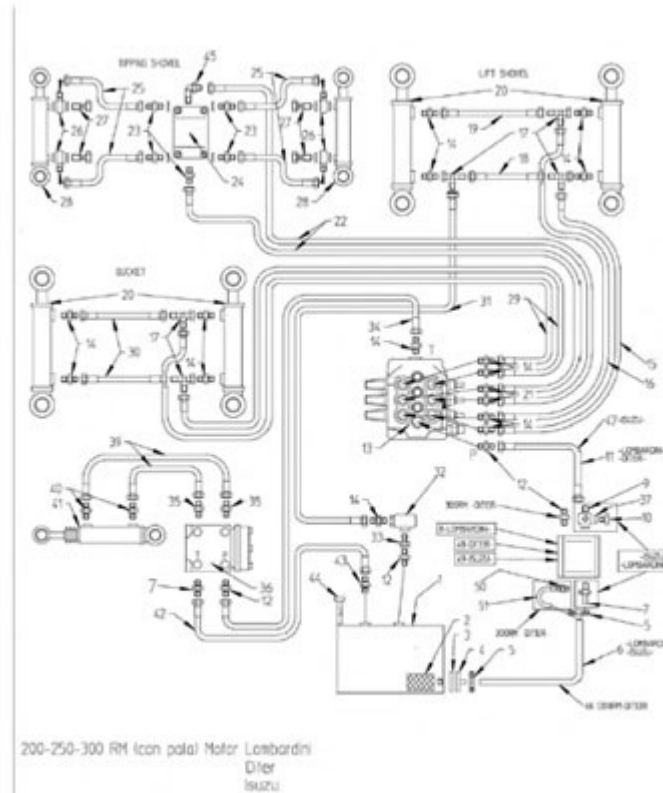

FIGURE	REFERENCE	DENOMINATION	AMOUNT
001	15.01420.03	TANK	1
002	09.00630.61	OIL FILTER ASP. 25 L/MIN	1
003	201.75003.50	O-RING DIN3770 75x81x3	1
004	02.01432.01	COVER HANDHOLE	1
005	912.20032.00	CLAMP	2
006	15.01615.00	TUBO GOMA B/P 15x25x1124	1
007	08.00301.00	NIPPLE M/TB 1/2G-D16	2
008	15.01205.00	HYDR. PUMP	1
009	08.00311.01	NIPPLE	1
010	08.00320.00	NIPPLE SCREW SIM.	1
011	51.01442.00	HOSE R2T1/2	1
012	08.00313.00	FITTING M/M 1/2 G-3/8 G	4
013	15.00330.00	CONTROL VALVE 3E	1
014	08.00319.00	NIPPLE M/M	14
015	54.01823.00	HOSE R1T3/8	1
016	43.01031.01	HOSE R1T3/8	1
017	44.01453.00	THREE-WAY UNION M/M/TL	5
018	15.01234.00	HOSE R1T3/8	1

SHOVEL APPLICATION HYDRAULIC INSTALLATION

FIGURE	REFERENCE	DENOMINATION	AMOUNT
019	15.01235.00	HOSE R1T3/8	1
020	08.00500.09	CYLINDER D/E	2
021	19.00720.00	NIPPLE M/M	2
022	15.40125.01	HOSE R1T1/4	2
024	45.01498.00	NIPPLE H/H/H/H	5
025	15.40126.00	HOSE R1T1/4	2
026	28.00339.00	NIPPLE O/M	4
027	28.00340.00	SIMPLE SCREW FITTING 1/4 Gx26	4
028	15.00670.01	CYLINDER D/E	2
029	54.01823.00	HOSE R1T3/8	2
030	10.00698.00	HOSE R1T3/8	2
031	08.00318.00	HOSE R1T3/8	1
032	47.01469.00	VALVE	1
033	60.13016.00	NIPPLE M/TL	1
034	45.01011.01	HOSE R1T3/8	1
035	52.00108.00	NIPPLE M/M	2
036	31.00613.00	STEERING VALVE	1
037	201.19002.50	O-RING DIN3770	1
038	08.00301.00	NIPPLE M/TB 1/2G-D16	1
039	46.50110.01	HOSE R1T1/4	2
040	19.00720.00	NIPPLE M/M	2
041	15.01050.02	CYLINDER D/E	1
042	15.01615.00	TUBO GOMA B/P 15x25x1124	1
043	08.00301.00	NIPPLE M/TB 1/2G-D16	1
044	09.00631.00	ROD OIL LEVEL	1
045	15.01453.00	ELBOW C90M/TL NIPPLE	1
046	15.01239.00	TUBO GOMA B/P 15x25x1500	1
047	51.01442.01	HOSE R2T1/2	1
048	15.01203.03	HYDR. PUMP	1
049	15.01157.00	HYDR. PUMP (ISUZU)	1
050	47.01432.00	NIPPLE M/M	1
051	08.30620.00	ADMISSION TUBE	1

INDEX

00. MAINTENANCE

Filters kit - 59188	2
Filters kit - 69892	3

02. ENGINE

MOTOR - 29295	4
MOTOR - 59188	6
MOTOR - 69892	7
EXHAUST PIPE	8
INLET - 44745	9
INLET - 69892	10
engine supports	11
engine supports - 59188	13
Isuzu engine supports - 44745	14
Clutch LOMBARDINI-DITER	15
Clutch LOMBARDINI-DITER - 59188	16
Clutch ISUZU	17
Gas-oil tank - 35217	18
ACCELERATOR - 59188	20

TRANSMISSION

Transmission fixating	21
Gearbox	22
Speed change	24
GEARBOX	26
Clutch bell housing - 34159	28
Clutch bell housing - 59188	29
Gears levers - 20547	30
Rear transmission coupling	32
Clutch operation - 44745	34

03. TRANSMISSION

REDUCTION BOX WITH COMPEN	36
SYSTEM COMPEN (PERMANENT 4WD SYSTEM)	38

TRANSMISSION

Housings and axles	39
Gear support and brake 250/300 RM	41

Gear support and brake 250/300 RM - 40782	43
Differential housing and gear - 31677	45
Shafts and hubs	46
Brake 250-300 RM	48
Rear axle	50
Gear support and brake Rear axle	52
Axles shaft and linkage support Rear axle	54
Differential housing and gear Rear axle - 31677	57
Steering cylinder REAR AXLE	58
Cardan joints RM	60
CARDAN JOINT COMPEN	61
04. CHASSIS	
Chassis - 44745	62
05. BRAKE ACTIVATION	
FOOT BRAKE	64
FOOT BRAKE - 69609	66
Handbrake	67
Brake	68
STEERING	
Steering	69
Steering - 63368	70
Steering - 79164	71
Wheel	
WHEELS	72
WHEELS - 58956	73
BODY	
Floor - 44745	74
Protectors - 45648	76
Protectors - 67306	78
Seat - 30339	80
MACHINE WORK	
HOPPER	81
Dumping cylinder - 43608	82

10. HYDRAULIC INSTALLATION

Working	84
Working - 59188	86
OIL TANK - 32274	88
Distributor	90

Electric Installation

Starting	91
Starting - 59188	92
Starting board - 45951	93
Starting board - 59188	94
Lighting	95
Lighting Panel - 50432	97

12. FINISHES

Plates - 44745	99
Plates - 70415	101

Option and variants

Driver protector roof - 39616	103
Windscreen wipers - 32859	105
Rear-vision mirror	106
Lights application	107

SHOVEL APPLICATION

Bucket arm	108
Arm cylinder support - 43608	110
Bucket cylinder	111
ARM CYLINDER - 43608	113
Hydraulic installation	114